

CITY MULTI

Air-Conditioners

PUMY-SP80, SP112, SP125, SP140VKMD

PUMY-SP80, SP112, SP125, SP140YKMD

For use with R410A

INSTALLATION MANUAL

For safe and correct use, read this manual and the indoor unit installation manual thoroughly before installing the air-conditioner unit.

FOR INSTALLER

English

Contents

1. Safety precautions.....	1	6. Electrical work	14
2. Installation location.....	3	7. Test run.....	23
3. Installing the outdoor unit	6	8. Special functions	24
4. Installing the refrigerant piping	6	9. Installation and operation manual for demand response (DRED).....	25
5. Drainage piping work.....	14		

⚠ Caution:

- Do not vent R410A into the atmosphere.

Confirmation of parts attached

In addition to this manual, the following part is supplied with the outdoor unit. It is used for grounding the S terminal of transmission terminal block TB7. For details refer to "6. Electrical work".

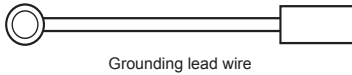

1. Safety precautions

- ▶ Before installing the unit, make sure you read all the "Safety precautions".
- ▶ Please report to or take consent by the supply authority before connection to the system.

⚠ Warning:

Describes precautions that must be observed to prevent danger of injury or death to the user.

⚠ Caution:

Describes precautions that must be observed to prevent damage to the unit.

⚠ Warning:

- The unit must not be installed by the user. Ask a dealer or an authorized technician to install the unit. If the unit is installed incorrectly, water leakage, electric shock, or fire may result.
- This appliance is intended to be used by expert or trained users in shops, in light industry and on farms, or for commercial use by lay persons.
- For installation work, follow the instructions in the Installation Manual and use tools and pipe components specifically made for use with R410A refrigerant. The R410A refrigerant in the HFC system is pressurized 1.6 times the pressure of usual refrigerants. If pipe components not designed for R410A refrigerant are used and the unit is not installed correctly, the pipes may burst and cause damage or injuries. In addition, water leakage, electric shock, or fire may result.
- When installing the unit, use appropriate protective equipment and tools for safety. Failure to do so could cause injuries.
- The unit must be installed according to the instructions in order to minimize the risk of damage from earthquakes, typhoons, or strong winds. An incorrectly installed unit may fall down and cause damage or injuries.
- The unit must be securely installed on a structure that can sustain its weight. If the unit is mounted on an unstable structure, it may fall down and cause damage or injuries.
- If the air conditioner is installed in a small room, measures must be taken to prevent the refrigerant concentration in the room from exceeding the safety limit in the event of refrigerant leakage. Consult a dealer regarding the appropriate measures to prevent the allowable concentration from being exceeded. Should the refrigerant leak and cause the concentration limit to be exceeded, hazards due to lack of oxygen in the room may result.
- Ventilate the room if refrigerant leaks during operation. If refrigerant comes into contact with a flame, poisonous gases will be released.
- All electric work must be performed by a qualified technician according to local regulations and the instructions given in this manual. The units must be powered by dedicated power lines and the correct voltage and circuit breakers must be used. Power lines with insufficient capacity or incorrect electrical work may result in electric shock or fire.
- Use C1220 copper phosphorus, for copper and copper alloy seamless pipes, to connect the refrigerant pipes. If the pipes are not connected correctly, the unit will not be properly grounded and electric shock may result.

After installation work has been completed, explain the "Safety Precautions," use, and maintenance of the unit to the customer according to the information in the Operation Manual and perform the test run to ensure normal operation. Both the Installation Manual and Operation Manual must be given to the user for keeping. These manuals must be passed on to subsequent users.

⚡: Indicates a part which must be grounded.

⚠ Warning:

Carefully read the labels affixed to the main unit.

- Use only specified cables for wiring. The wiring connections must be made securely with no tension applied on the terminal connections. Also, never splice the cables for wiring (unless otherwise indicated in this document). Failure to observe these instructions may result in overheating or a fire.
- The terminal block cover panel of the outdoor unit must be firmly attached. If the cover panel is mounted incorrectly and dust and moisture enter the unit, electric shock or fire may result.
- The appliance shall be installed in accordance with national wiring regulations.
- If the supply cord is damaged, it must be replaced by the manufacturer, its service agent or similarly qualified persons in order to avoid a hazard.
- When installing or relocating, or servicing the air conditioner, use only the specified refrigerant (R410A) to charge the refrigerant lines. Do not mix it with any other refrigerant and do not allow air to remain in the lines. If air is mixed with the refrigerant, then it can be the cause of abnormal high pressure in the refrigerant line, and may result in an explosion and other hazards. The use of any refrigerant other than that specified for the system will cause mechanical failure or system malfunction or unit breakdown. In the worst case, this could lead to a serious impediment to securing product safety.
- Use only authorized accessories and ask a dealer or an authorized technician to install them. If accessories are incorrectly installed, water leakage, electric shock, or fire may result.
- Do not alter the unit. It may cause fire, electric shock, injury or water leakage.
- The user should never attempt to repair the unit or transfer it to another location. If the unit is installed incorrectly, water leakage, electric shock, or fire may result. If the air conditioner must be repaired or moved, ask a dealer or an authorized technician.
- After installation has been completed, check for refrigerant leaks. If refrigerant leaks into the room and comes into contact with the flame of a heater or portable cooking range, poisonous gases will be released.
- When opening or closing the valve below freezing temperatures, refrigerant may spurt out from the gap between the valve stem and the valve body, resulting in injuries.

1. Safety precautions

1.1. Before installation

⚠ Caution:

- Do not use the unit in an unusual environment. If the air conditioner is installed in areas exposed to steam, volatile oil (including machine oil), or sulfuric gas, areas exposed to high salt content such as the seaside, or areas where the unit will be covered by snow, the performance can be significantly reduced and the internal parts can be damaged.
- Do not install the unit where combustible gases may leak, be produced, flow, or accumulate. If combustible gas accumulates around the unit, fire or explosion may result.
- The outdoor unit produces condensation during the heating operation. Make sure to provide drainage around the outdoor unit if such condensation is likely to cause damage.
- When installing the unit in a hospital or communications office, be prepared for noise and electronic interference. Inverters, home appliances, high-frequency medical equipment, and radio communications equipment can cause the air conditioner to malfunction or breakdown. The air conditioner may also affect medical equipment, disturbing medical care, and communications equipment, harming the screen display quality.

1.2. Before installation (relocation)

⚠ Caution:

- Be extremely careful when transporting the units. Two or more persons are needed to handle the unit, as it weighs 20 kg or more. Do not grasp the packaging bands. Wear protective gloves to remove the unit from the packaging and to move it, as you can injure your hands on the fins or other parts.
- Be sure to safely dispose of the packaging materials. Packaging materials, such as nails and other metal or wooden parts may cause stabs or other injuries.
- The base and attachments of the outdoor unit must be periodically checked for looseness, cracks or other damage. If such defects are left uncorrected, the unit may fall down and cause damage or injuries.
- Do not clean the air conditioner unit with water. Electric shock may result.
- Tighten all flare nuts to specification using a torque wrench. If tightened too much, the flare nut can break after an extended period and refrigerant can leak out.

1.3. Before electric work

⚠ Caution:

- Be sure to install circuit breakers. If not installed, electric shock may result.
- For the power lines, use standard cables of sufficient capacity. Otherwise, a short circuit, overheating, or fire may result.
- When installing the power lines, do not apply tension to the cables. If the connections are loosened, the cables can snap or break and overheating or fire may result.
- Be sure to ground the unit. Do not connect the ground wire to gas or water pipes, lightning rods, or telephone grounding lines. If the unit is not properly grounded, electric shock may result.
- Use circuit breakers (ground fault interrupter, isolating switch (+B fuse), and molded case circuit breaker) with the specified capacity. If the circuit breaker capacity is larger than the specified capacity, breakdown or fire may result.

1.4. Before starting the test run

⚠ Caution:

- Turn on the main power switch more than 12 hours before starting operation. Starting operation just after turning on the power switch can severely damage the internal parts. Keep the main power switch turned on during the operation season.
- Before starting operation, check that all panels, guards and other protective parts are correctly installed. Rotating, hot, or high voltage parts can cause injuries.
- Do not touch any switch with wet hands. Electric shock may result.
- Do not touch the refrigerant pipes with bare hands during operation. The refrigerant pipes are hot or cold depending on the condition of the flowing refrigerant. If you touch the pipes, burns or frostbite may result.
- After stopping operation, be sure to wait at least five minutes before turning off the main power switch. Otherwise, water leakage or breakdown may result.

1.5. Using R410A refrigerant air conditioners

⚠ Caution:

- Use C1220 copper phosphorus, for copper and copper alloy seamless pipes, to connect the refrigerant pipes. Make sure the insides of the pipes are clean and do not contain any harmful contaminants such as sulfuric compounds, oxidants, debris, or dust. Use pipes with the specified thickness. (Refer to 4.1.) Note the following if reusing existing pipes that carried R22 refrigerant.
 - Replace the existing flare nuts and flare the flared sections again.
 - Do not use thin pipes. (Refer to 4.1.)
- Store the pipes to be used during installation indoors and keep both ends of the pipes sealed until just before brazing. (Leave elbow joints, etc. in their packaging.) If dust, debris, or moisture enters the refrigerant lines, oil deterioration or compressor breakdown may result.
- Use ester oil, ether oil, alkylbenzene oil (small amount) as the refrigeration oil applied to the flared sections. If mineral oil is mixed in the refrigeration oil, oil deterioration may result.
- Do not use refrigerant other than R410A refrigerant. If another refrigerant is used, the chlorine will cause the oil to deteriorate.
- Use the following tools specifically designed for use with R410A refrigerant. The following tools are necessary to use R410A refrigerant. Contact your nearest dealer for any questions.

Tools (for R410A)	
Gauge manifold	Flare tool
Charge hose	Size adjustment gauge
Gas leak detector	Vacuum pump adapter
Torque wrench	Electronic refrigerant charging scale

- Be sure to use the correct tools. If dust, debris, or moisture enters the refrigerant lines, refrigeration oil deterioration may result.
- Do not use a charging cylinder. If a charging cylinder is used, the composition of the refrigerant will change and the efficiency will be lowered.

2. Installation location

2.1. Refrigerant pipe

Refer to Fig. 4-1, 4-2.

2.2. Choosing the outdoor unit installation location

- Avoid locations exposed to direct sunlight or other sources of heat.
- Select a location from which noise emitted by the unit will not inconvenience neighbors.
- Select a location permitting easy wiring and pipe access to the power source and indoor unit.
- Avoid locations where combustible gases may leak, be produced, flow, or accumulate.
- Note that water may drain from the unit during operation.
- Select a level location that can bear the weight and vibration of the unit.
- Avoid locations where the unit can be covered by snow. In areas where heavy snow fall is anticipated, special precautions such as raising the installation location or installing a hood on the air intake must be taken to prevent the snow from blocking the air intake or blowing directly against it. This can reduce the airflow and a malfunction may result.
- Avoid locations exposed to oil, steam, or sulfuric gas.
- Use the transportation handles of the outdoor unit to transport the unit. If the unit is carried from the bottom, hands or fingers may be pinched.

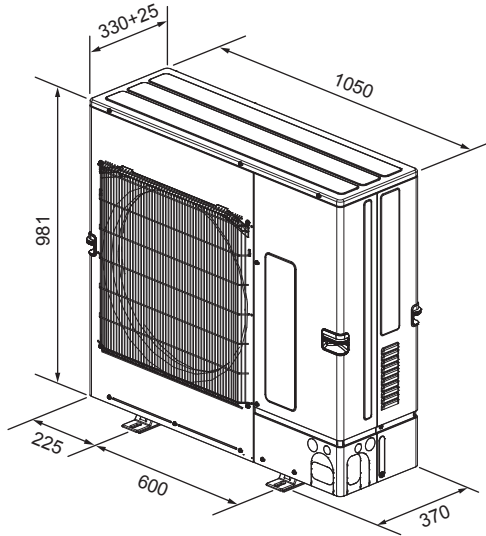

Fig. 2-1

(mm)

2.3. Outline dimensions (Outdoor unit) (Fig. 2-1)

Constraints on indoor unit installation

You should note that indoor units that can be connected to this outdoor unit are the following models.

- Indoor units with model numbers 10-140 can be connected.
- When using Branch box, Indoor units with model numbers 22-100 can be connected.

Refer to the table 1 below for possible room, indoor unit combinations.

Verification

The rated capacity should be determined by observing the table below. The unit's quantities are limited as shown in the following table 2. For the next step, make sure that the total rated capacity selected will stay in a range of 50% – 130% of the outdoor unit capacity.

- PUMY-SP80 4.5 – 11.7 kW
- PUMY-SP112 6.3 – 16.2 kW
- PUMY-SP125 7.1 – 18.2 kW
- PUMY-SP140 8.0 – 20.2 kW

Table 1-1 City Multi indoor units

Indoor unit type	10	15	20	25	32	40	50	63	71	80	100	125	140
Rated capacity (Cooling) (kW)	1.2	1.7	2.2	2.8	3.6	4.5	5.6	7.1	8.0	9.0	11.2	14.0	16.0

Table 1-2 M, S, P series

Indoor unit type	22	25	35	42	50	60	71	80	100
Rated capacity (Cooling) (kW)	2.2	2.5	3.5	4.2	5.0	6.0	7.1	8.0	10.0

Table 2 Connectable indoor units quantities

Model	Only system		Mixed system			
	Only City Multi indoor units (Connection without Branch box)	Only M, S, P series indoor units (Connection with Branch box)	One Branch box		Two Branch box	
			Connection with Branch box	City Multi indoor units	Connection with Branch box	City Multi indoor units
PUMY-SP80	1-9	2-5	Max. 2 Units	Max. 5 Units	Max. 3 Units	Max. 3 Units
			Max. 3 Units	Max. 4 Units		
			Max. 4 Units	Max. 2 Units	Max. 4 Units	Max. 2 Units
PUMY-SP112	1-12	2-7	Max. 4 Units	Max. 5 Units	Max. 5 Units	Max. 3 Units
			Max. 5 Units	Max. 4 Units	Max. 6 Units	Max. 2 Units
PUMY-SP125	1-12	2-8	Max. 5 Units	Max. 5 Units	Max. 6 Units	Max. 3 Units
					Max. 7 Units	Max. 2 Units
PUMY-SP140	1-12	2-8	Max. 5 Units	Max. 5 Units	Max. 7 Units	Max. 3 Units
					Max. 8 Units	Max. 2 Units

Table 3 Connectable Branch box quantities

Model	Branch box
PUMY-SP80/112/125/140	1-2

Combinations in which the total capacity of indoor units exceeds the capacity of the outdoor unit will reduce the cooling capacity of each indoor unit below their rated cooling capacity. Thus, combine indoor units with an outdoor unit within the outdoor unit's capacity, if possible.

2. Installation location

2.4. Connecting a PEFY-P-VMA3-E

When using a PEFY-P-VMA3-E, use the following combinations for the connected indoor units.

	PUMY-SP80	PUMY-SP112	PUMY-SP125	PUMY-SP140
OK	PEFY-P20VMA3-E × 4	PEFY-P25VMA3-E × 2 + PEFY-P32VMA3-E × 2	PEFY-P25VMA3-E × 1 + PEFY-P32VMA3-E × 3	PEFY-P32VMA3-E × 2 + PEFY-P40VMA3-E × 2
NG	All combinations excluding the above combinations Ex. 1: PEFY-P20VMA3-E × 2 + PEFY-P20VMA-E × 2 Ex. 2: PEFY-P20VMA3-E × 3 Ex. 3: PEFY-P25VMA3-E × 1 + PEFY-P32VMA3-E × 3 (A combination for a PUMY-SP125) Ex. 4: PEFY-P20VMA3-E × 4 + MSZ-FH25VE × 1	All combinations excluding the above combinations Ex. 1: PEFY-P25VMA3-E × 2 + PEFY-P32VMA-E × 2 Ex. 2: PEFY-P25VMA3-E × 2 + PEFY-P32VMA3-E × 1 Ex. 3: PEFY-P25VMA3-E × 1 + PEFY-P32VMA3-E × 3 (A combination for a PUMY-SP125) Ex. 4: PEFY-P25VMA3-E × 2 + PEFY-P32VMA3-E × 2 + MSZ-FH25VE × 1	All combinations excluding the above combinations Ex. 1: PEFY-P32VMA3-E × 3 + PEFY-P32VMA-E × 1 Ex. 2: PEFY-P32VMA3-E × 3 Ex. 3: PEFY-P25VMA3-E × 2 + PEFY-P32VMA3-E × 2 (A combination for a PUMY-SP112) Ex. 4: PEFY-P32VMA3-E × 3 + PLFY-P20VFM-E × 1 + SEZ-KD25VA × 1	All combinations excluding the above combinations Ex. 1: PEFY-P32VMA3-E × 3 + PEFY-P40VMA-E × 1 Ex. 2: PEFY-P32VMA3-E × 2 + PEFY-P40VMA3-E × 1 Ex. 3: PEFY-P25VMA3-E × 1 + PEFY-P32VMA3-E × 3 (A combination for a PUMY-SP125) Ex. 4: PEFY-P32VMA3-E × 3 + PCFY-P40VKM-E × 1 + MSZ-FH25VE × 1

Ex. 1: A ceiling-concealed unit other than a VMA3 series is selected. Combinations with a ceiling-concealed different series are not possible.
Ex. 2: The number of units is incorrect.
Ex. 3: The combination is for a unit with a different capacity.
Ex. 4: The combination is not an "OK" combination.

2. Installation location

2.5. Ventilation and service space

2.5.1. When installing a single outdoor unit

Minimum dimensions are as follows, except for Max., meaning Maximum dimensions, indicated.

Refer to the figures for each case.

- ① Obstacles at rear only (Fig. 2-2)
- ② Obstacles at rear and above only (Fig. 2-3)
- ③ Obstacles at rear and sides only (Fig. 2-4)
- ④ Obstacles at front only (Fig. 2-5)
 - * When using an optional air outlet guide, the clearance is 500 mm or more.
- ⑤ Obstacles at front and rear only (Fig. 2-6)
 - * When using an optional air outlet guide, the clearance is 500 mm or more.
- ⑥ Obstacles at rear, sides, and above only (Fig. 2-7)
 - * Do not install the optional air outlet guides for upward airflow.

2.5.2. When installing multiple outdoor units

Leave 25 mm space or more between the units.

- ① Obstacles at rear only (Fig. 2-8)
- ② Obstacles at rear and above only (Fig. 2-9)
 - No more than 3 units must be installed side by side. In addition, leave space as shown.
 - Do not install the optional air outlet guides for upward airflow.
- ③ Obstacles at front only (Fig. 2-10)
 - * When using an optional air outlet guide, the clearance is 1000 mm or more.
- ④ Obstacles at front and rear only (Fig. 2-11)
 - * When using an optional air outlet guide, the clearance is 1000 mm or more.
- ⑤ Single parallel unit arrangement (Fig. 2-12)
 - * When using an optional air outlet guide installed for upward airflow, the clearance is 1000 mm or more.
- ⑥ Multiple parallel unit arrangement (Fig. 2-13)
 - * When using an optional air outlet guide installed for upward airflow, the clearance is 1500 mm or more.
- ⑦ Stacked unit arrangement (Fig. 2-14)
 - The units can be stacked up to 2 units high.
 - No more than 2 stacked units must be installed side by side. In addition, leave space as shown.

UNIT: mm

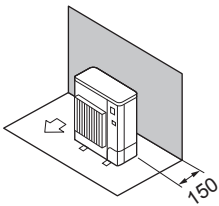

Fig. 2-2

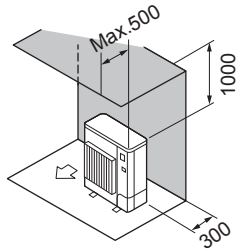

Fig. 2-3

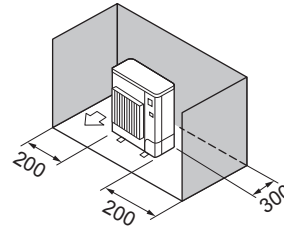

Fig. 2-4

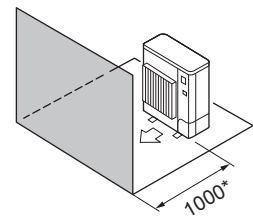

Fig. 2-5

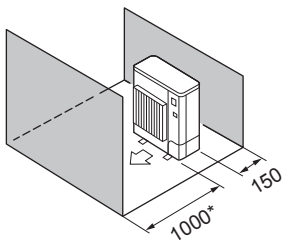

Fig. 2-6

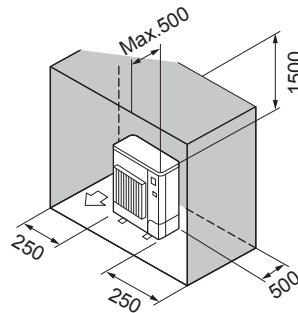

Fig. 2-7

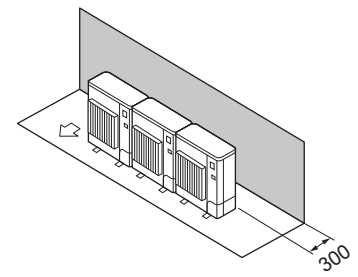

Fig. 2-8

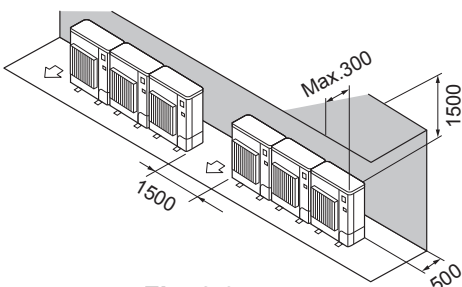

Fig. 2-9

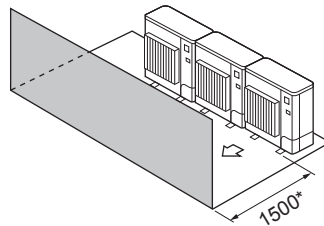

Fig. 2-10

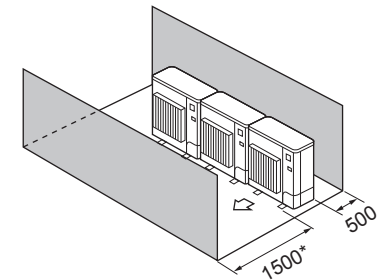

Fig. 2-11

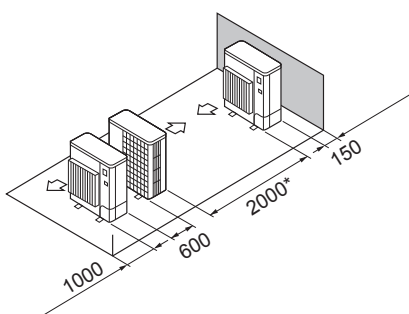

Fig. 2-12

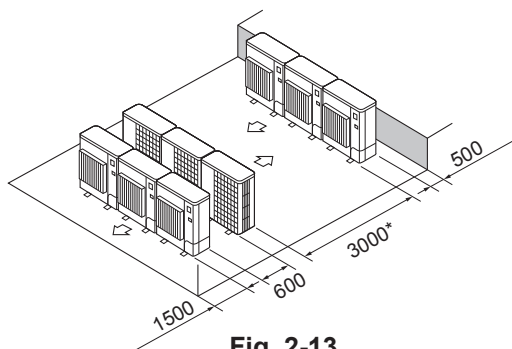

Fig. 2-13

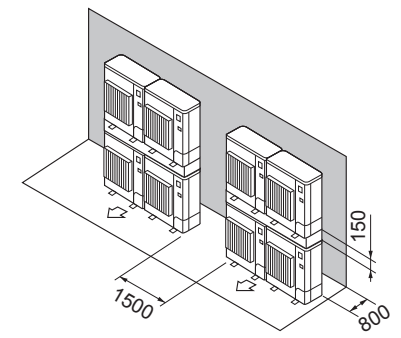

Fig. 2-14

2. Installation location

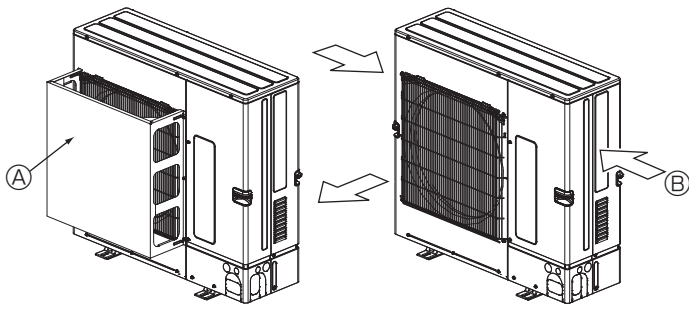

Fig. 2-15

Fig. 2-16

2.5.3. Windy location installation

When installing the outdoor unit on a rooftop or other location unprotected from the wind, situate the air outlet of the unit so that it is not directly exposed to strong winds. Strong wind entering the air outlet may impede the normal airflow and a malfunction may result.

The following shows two examples of precautions against strong winds.

- ① Install an optional air protect guide if the unit is installed in a location where strong winds from a typhoon, etc. may directly enter the air outlet. (Fig. 2-15)
 - Ⓐ Air protect guide
- ② Position the unit so that the air outlet blows perpendicularly to the seasonal wind direction, if possible. (Fig. 2-16)
 - Ⓔ Wind direction

3. Installing the outdoor unit

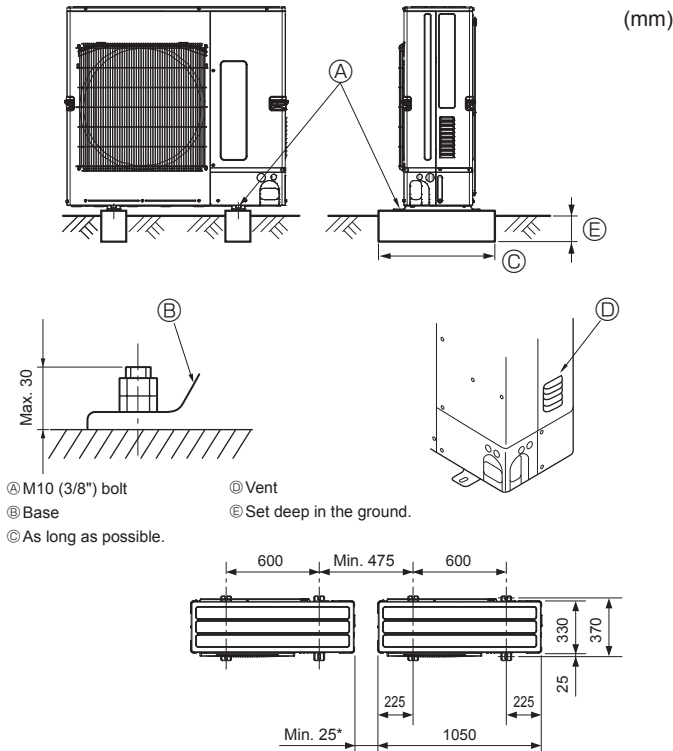

(mm)

- Be sure to install the unit in a sturdy, level surface to prevent rattling noises during operation. (Fig. 3-1)

<Foundation specifications>

Foundation bolt	M10 (3/8")
Thickness of concrete	120 mm
Length of bolt	70 mm
Weight-bearing capacity	320 kg

- Make sure that the length of the foundation bolt is within 30 mm of the bottom surface of the base.

- Secure the base of the unit firmly with four-M10 foundation bolts in sturdy locations.

Installing the outdoor unit

- Do not block the vent. If the vent is blocked, operation will be hindered and breakdown may result.

- In addition to the unit base, use the installation holes on the back of the unit to attach wires, etc., if necessary to install the unit. Use self-tapping screws (ø5 × 15 mm or less) and install on site.

⚠ Warning:

- The unit must be securely installed on a structure that can sustain its weight. If the unit is mounted on an unstable structure, it may fall down and cause damage or injuries.
- The unit must be installed according to the instructions in order to minimize the risk of damage from earthquakes, typhoons, or strong winds. An incorrectly installed unit may fall down and cause damage or injuries.

⚠ Caution:

- Install unit on a rigid structure to prevent excessive operation sound or vibration.

Fig. 3-1

4. Installing the refrigerant piping

4.1. Precautions for devices that use R410A refrigerant

- Refer to 1.5. for precautions not included below on using air conditioners with R410A refrigerant.
- Use ester oil, ether oil, alkylbenzene oil (small amount) as the refrigeration oil applied to the flared sections.
- Use C1220 copper phosphorus, for copper and copper alloy seamless pipes, to connect the refrigerant pipes. Use refrigerant pipes with the thicknesses specified in the table to the below. Make sure the insides of the pipes are clean and do not contain any harmful contaminants such as sulfuric compounds, oxidants, debris, or dust.

⚠ Warning:

When installing or relocating, or servicing the air conditioner, use only the specified refrigerant (R410A) to charge the refrigerant lines. Do not mix it with any other refrigerant and do not allow air to remain in the lines. If air is mixed with the refrigerant, then it can be the cause of abnormal high pressure in the refrigerant line, and may result in an explosion and other hazards. The use of any refrigerant other than that specified for the system will cause mechanical failure or system malfunction or unit breakdown. In the worst case, this could lead to a serious impediment to securing product safety.

Pipe size (mm)	ø6.35	ø9.52	ø12.7	ø15.88
Thickness (mm)	0.8	0.8	0.8	1.0

- Do not use pipes thinner than those specified above.
- The thicknesses listed in the table above are based on Japanese standards. Use pipes with a maximum working pressure of 4.15 MPa [601 PSIG] or higher according to local standards.

4. Installing the refrigerant piping

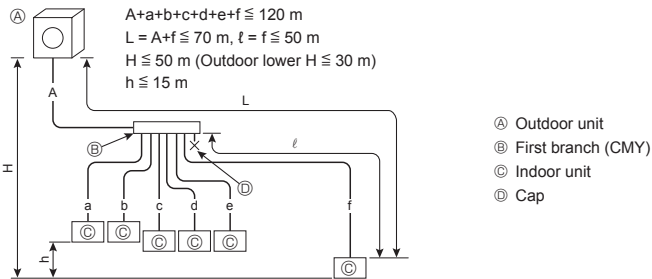
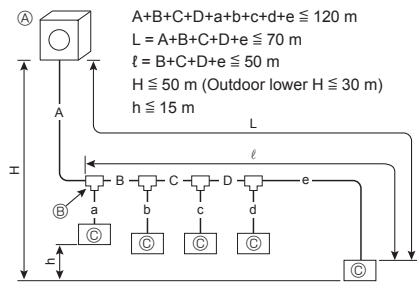

Fig. 4-1

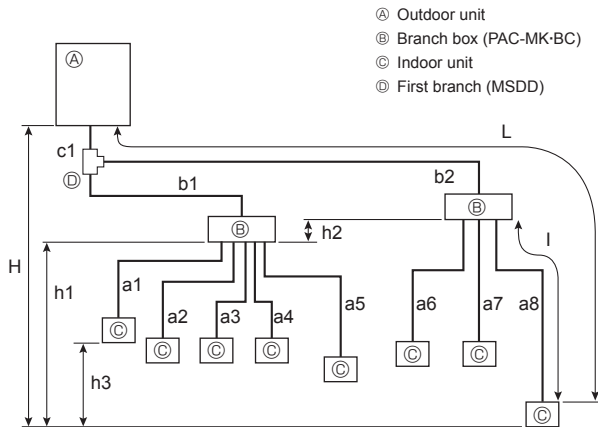

Fig. 4-2

Permissible length (one-way)	Total piping length	$c1 + b1 + b2 + a1 + a2 + a3 + a4 + a5 + a6 + a7 + a8 \leq 120$ m
	Farthest piping length (L)	$c1 + b2 + a8 \leq 80$ m
	Piping length between outdoor unit and branch boxes	$c1 + b1 + b2 \leq 55$ m
	Farthest branch box from the first joint (b2)	$b2 \leq 50$ m
	Farthest piping length after branch box (l)	$a8 \leq 25$ m
	Total piping length between branch boxes and indoor units	$a1 + a2 + a3 + a4 + a5 + a6 + a7 + a8 \leq 95$ m
Permissible height difference (one-way)	In indoor/outdoor section (H)*1	$H \leq 50$ m (In case of outdoor unit is set higher than indoor unit) $H \leq 30$ m (In case of outdoor unit is set lower than indoor unit)
	In branch box/indoor unit section (h1)	$h1 + h2 \leq 15$ m
	In each branch unit (h2)	$h2 \leq 15$ m
	In each indoor unit (h3)	$h3 \leq 12$ m
Number of bends	$c1 + b1 + a1$, $c1 + b1 + a2$, $c1 + b1 + a3$, $c1 + b1 + a4$, $c1 + b1 + a5$, $c1 + b2 + a6$, $c1 + b2 + a7$, $c1 + b2 + a8$ ≤ 15	

*1 Branch box should be placed within the level between the outdoor unit and indoor units.

4.1.1. Connection without Branch box (Fig. 4-1)

A (mm)	
A Liquid pipe	B Gas pipe
$\phi 9.52$	$\phi 15.88$

L: The farthest piping length from the outdoor unit to an indoor unit.

B, C, D (mm)	
A Liquid pipe	B Gas pipe
$\phi 9.52$	$\phi 15.88$

L: The farthest piping length from the outdoor unit to an indoor unit.

a, b, c, d, e, f (mm)		
D Model number	A Liquid pipe	B Gas pipe
10, 15, 20, 25, 32, 40, 50	a, b, c, d, e, f ≤ 30 m	$\phi 6.35$
	a, b, c, d, e, f > 30 m	$\phi 9.52^{*1}$
63, 71, 80, 100, 125, 140	$\phi 9.52$	$\phi 15.88$

*1 If the piping length after the first joint exceeds 30 m, use a pipe size of $\phi 9.52$ for the pipes of the system that exceeds 30 m.

E Branch kit model	
CMY-Y62-G-E	

F 4-Branching header		G 8-Branching header	
CMY-Y64-G-E		CMY-Y68-G-E	

* When connecting the CONNECTION KIT (PAC-LV11M-J) and an M-series indoor unit, refer to the installation manual for the CONNECTION KIT when selecting the pipe size and piping length.

4.1.2. Connection with Branch box (Fig. 4-2)

Flared connections

- This unit has flared connections on each indoor unit and branch box and outdoor unit sides.
- Remove the valve cover of the outdoor unit, then connect the pipe.
- Refrigerant pipes are used to connect the branch box and outdoor unit.

4. Installing the refrigerant piping

■ In case of using 1-branch box

Flare connection employed. (No. brazing)

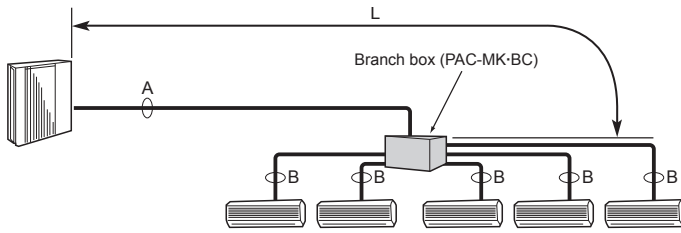

■ In case of using 2-branch boxes

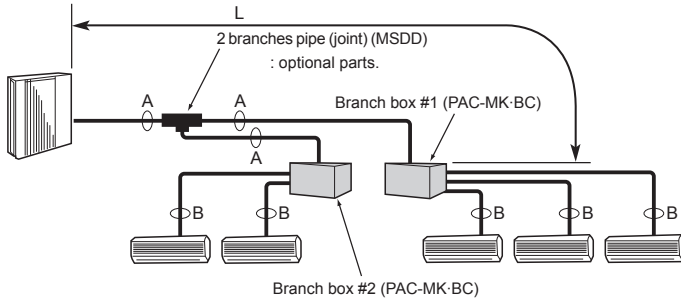

Fig. 4-3

(1) Valve size for outdoor unit

For liquid	ø9.52 mm
For gas	ø15.88 mm

(2) Valve size for branch box

UNIT	Pipe	Valve size
A UNIT	Liquid pipe	ø6.35 mm
	Gas pipe	ø9.52 mm
B UNIT	Liquid pipe	ø6.35 mm
	Gas pipe	ø9.52 mm
C UNIT	Liquid pipe	ø6.35 mm
	Gas pipe	ø9.52 mm
D UNIT	Liquid pipe	ø6.35 mm
	Gas pipe	ø9.52 mm
E UNIT	Liquid pipe	ø6.35 mm
	Gas pipe	ø12.7 mm

* 3-branch type : only A, B, C unit

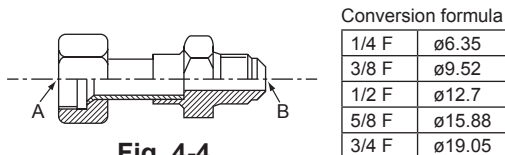

Fig. 4-4

Conversion formula

1/4 F	ø6.35
3/8 F	ø9.52
1/2 F	ø12.7
5/8 F	ø15.88
3/4 F	ø19.05



Fig. 4-5

Selecting pipe size (Fig. 4-3)

	A	B
Liquid (mm)	ø9.52	The piping connection size differs according to the type and capacity of indoor units. Match the piping connection size of branch box with indoor unit. If the piping connection size of branch box does not match the piping connection size of indoor unit, use optional different-diameter (deformed) joints to the branch box side. (Connect deformed joint directly to the branch box side.)
Gas (mm)	ø15.88	

L: The farthest piping length for the main pipes from the outdoor unit to the branch box.

Different-diameter joint (optional parts) (Fig. 4-4)

Model name	Connected pipes diameter	Diameter A	Diameter B
	mm	mm	mm
MAC-A454JP	ø9.52 → ø12.7	ø9.52	ø12.7
MAC-A455JP	ø12.7 → ø9.52	ø12.7	ø9.52
MAC-A456JP	ø12.7 → ø15.88	ø12.7	ø15.88
PAC-493PI	ø6.35 → ø9.52	ø6.35	ø9.52
PAC-SG76RJ-E	ø9.52 → ø15.88	ø9.52	ø15.88

Different-diameter joint (optional parts) (Fig. 4-5)

Model name	Connected pipes diameter	Outside Diameter A	Inside Diameter B
	mm	mm	mm
PAC-SG78RJB-E	ø9.52 → ø12.7	ø9.52	ø12.7
PAC-SG79RJB-E	ø12.7 → ø9.52	ø12.7	ø9.52
PAC-SG80RJB-E	ø12.7 → ø15.88	ø12.7	ø15.88
PAC-SG77RJB-E	ø6.35 → ø9.52	ø6.35	ø9.52
PAC-SG76RJB-E	ø9.52 → ø15.88	ø9.52	ø15.88

2-branches pipe (Joint) : Optional parts (According to the connection method, you can choose the favorite one.)

Model name	Connection method
MSDD-50AR-E	flare

■ Installation procedure (2 branches pipe (Joint))

Refer to the installation manuals of MSDD-50AR-E.

■ Pipe size (Outdoor unit-Branch box)

Pipe size (ømm)	Liquid	Gas
		ø9.52

The lineup of a connectable indoor unit depends on a district/areas/country.

■ Branch box

Model name	Number of connected units
PAC-MK3*BC	3-branches (Max. 3 units)
PAC-MK5*BC	5-branches (Max. 5 units)

Note: * = 0, 1, 2,

The PAC-MK31/32BC and PAC-MK51/52BC cannot be connected.

■ Pipe size (Branch box-Indoor unit) Case of M series or S series indoor unit

Indoor unit type	(kW)	22 - 42	50	60	71 - 80
	Pipe size (ømm)	Liquid	ø6.35	ø6.35	ø9.52
	Gas	ø9.52	ø12.7	ø15.88	ø15.88

* If the pipe size of indoor unit is different, use a different-diameter joint.

■ Pipe size (Branch box-Indoor unit) Case of P series indoor unit

Indoor unit type	(kW)	35 - 50	60 - 100
	Pipe size (ømm)	Liquid	ø6.35
	Gas	ø12.7	ø15.88

*1 The lineup of a connectable indoor unit depends on a district/areas/country.

*2 When using 35, 50 type indoor unit of P series, use the flare nut attached to the indoor unit.

Do not use the flare nut in the indoor unit accessory. If it is used, a gas leakage or even a pipe extraction may occur.

4. Installing the refrigerant piping

4.1.3. Mixed system (City Multi indoor units and M, S, P series indoor units via Branch box)

4.1.3-1 In case of using 1-branch box

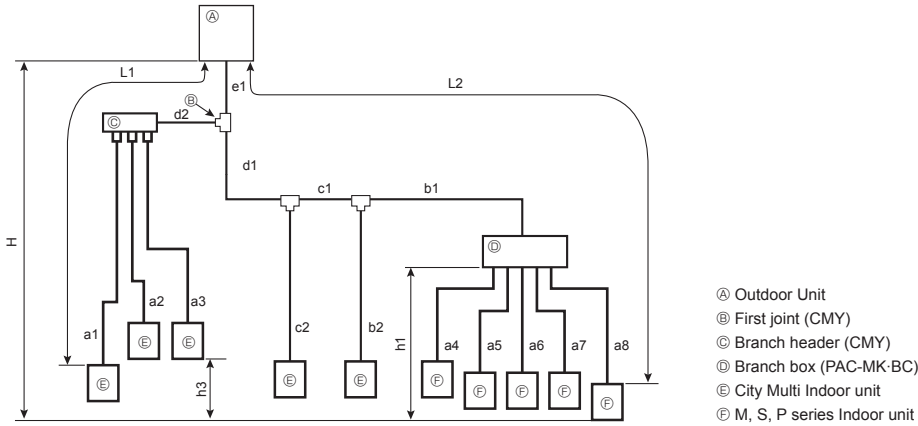

Permissible length (One-way)	Total piping length	$e1 + d1 + d2 + c1 + c2 + b1 + b2 + a1 + a2 + a3 + a4 + a5 + a6 + a7 + a8 \leq 120 \text{ m}$
	Farthest piping length (L1)	$e1 + d2 + a1 \text{ or } e1 + d1 + c1 + b2 \leq 70 \text{ m}$
	Farthest piping length. Via Branch box (L2)	$e1 + d1 + c1 + b1 + a8 \leq 80 \text{ m}$
	Piping length between outdoor unit and branch box	$e1 + d1 + c1 + b1 \leq 55 \text{ m}$
	Farthest piping length from the first joint	$d1 + c1 + b1 \text{ or } d2 + a1 \leq 50 \text{ m}$
	Farthest piping length after branch box	$a8 \leq 25 \text{ m}$
	Total piping length between branch boxes and indoor units	$a4 + a5 + a6 + a7 + a8 \leq 95 \text{ m}$
Permissible height difference (One-way)	In indoor/outdoor section (H) *1	$H \leq 50 \text{ m}$ (In case of outdoor unit is set higher than indoor unit) $H \leq 30 \text{ m}$ (In case of outdoor unit is set lower than indoor unit)
	In branch box/indoor unit section (h1)	$h1 \leq 15 \text{ m}$
	In each indoor unit (h3)	$h3 \leq 12 \text{ m}$
Number of bends		$ e1 + d2 + a1 , e1 + d2 + a2 , e1 + d2 + a3 , e1 + d1 + c2 , e1 + d1 + c1 + b2 , e1 + d1 + c1 + b1 + a4 , e1 + d1 + c1 + b1 + a5 , e1 + d1 + c1 + b1 + a6 , e1 + d1 + c1 + b1 + a7 , e1 + d1 + c1 + b1 + a8 \leq 15$

*1: Branch box should be placed within the level between the outdoor unit and indoor units.

4.1.3-2 In case of using 2-branch boxes

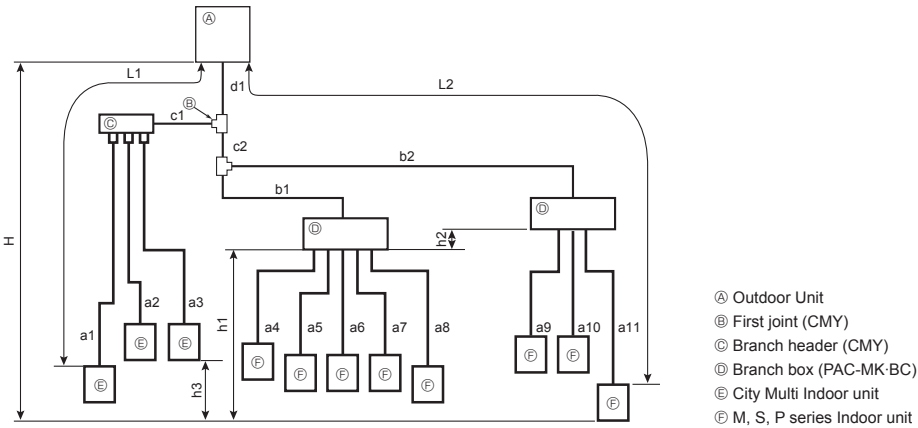

Permissible length (One-way)	Total piping length	$d1 + c1 + c2 + b1 + b2 + a1 + a2 + a3 + a4 + a5 + a6 + a7 + a8 + a9 + a10 + a11 \leq 120 \text{ m}$
	Farthest piping length (L1)	$d1 + c1 + a1 \leq 70 \text{ m}$
	Farthest piping length. Via Branch box (L2)	$d1 + c2 + b2 + a11 \leq 80 \text{ m}$
	Piping length between outdoor unit and branch boxes	$d1 + c2 + b1 + b2 \leq 55 \text{ m}$
	Farthest piping length from the first joint	$c2 + b2 \text{ or } c1 + a1 \leq 50 \text{ m}$
	Farthest piping length after branch box	$a11 \leq 25 \text{ m}$
	Total piping length between branch boxes and indoor units	$a4 + a5 + a6 + a7 + a8 + a9 + a10 + a11 \leq 95 \text{ m}$
Permissible height difference (One-way)	In indoor/outdoor section (H) *1	$H \leq 50 \text{ m}$ (In case of outdoor unit is set higher than indoor unit) $H \leq 30 \text{ m}$ (In case of outdoor unit is set lower than indoor unit)
	In branch box/indoor unit section (h1+h2)	$h1 + h2 \leq 15 \text{ m}$
	In each branch unit (h1)	$h2 \leq 15 \text{ m}$
	In each indoor unit (h3)	$h3 \leq 12 \text{ m}$
Number of bends		$ d1 + c1 + a1 , d1 + c1 + a2 , d1 + c1 + a3 , d1 + c2 + b1 + a4 , d1 + c2 + b1 + a5 , d1 + c2 + b1 + a6 , d1 + c2 + b1 + a7 , d1 + c2 + b1 + a8 , d1 + c2 + b2 + a9 , d1 + c2 + b2 + a10 , d1 + c2 + b2 + a11 \leq 15$

*1: Branch box should be placed within the level between the outdoor unit and indoor units.

4. Installing the refrigerant piping

4.1.3-3 Selecting pipe size System pipe size

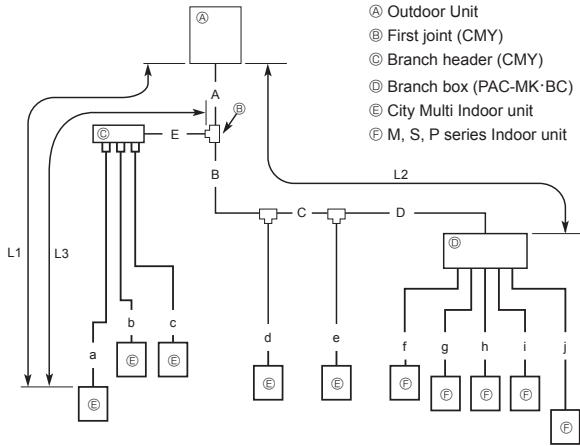

Branch box pipe size

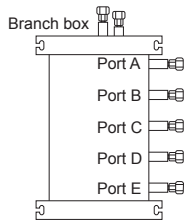

(1) Valve size for outdoor unit

For liquid	ø9.52 mm
For gas	ø15.88 mm

(2) Valve size for branch box

UNIT	Liquid pipe		Gas pipe	
	ø	mm	ø	mm
A UNIT	ø6.35	mm	ø9.52	mm
	ø6.35	mm	ø9.52	mm
B UNIT	ø6.35	mm	ø9.52	mm
	ø6.35	mm	ø9.52	mm
C UNIT	ø6.35	mm	ø9.52	mm
	ø6.35	mm	ø9.52	mm
D UNIT	ø6.35	mm	ø9.52	mm
	ø6.35	mm	ø9.52	mm
E UNIT	ø6.35	mm	ø12.7	mm
	ø6.35	mm	ø12.7	mm

* 3-branch type : only A, B, C unit

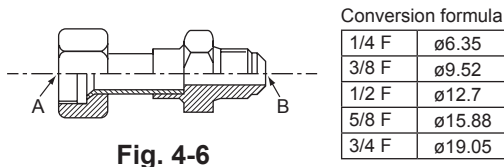

Conversion formula

1/4 F	ø6.35
3/8 F	ø9.52
1/2 F	ø12.7
5/8 F	ø15.88
3/4 F	ø19.05

Fig. 4-6



Fig. 4-7

Pipe size

A, B, C, D, E

A Liquid pipe	B Gas pipe
ø9.52	ø15.88

L1: The farthest piping length from the outdoor unit to an indoor unit.

L2: The farthest piping length for the main pipes from the outdoor unit to the branch box.

L3: The farthest piping length from the first joint.

a, b, c - j

Indoor unit series	Model number	A Liquid pipe		B Gas pipe
		L3 ≤ 30m	L3 > 30m	
City Multi	10 - 50	ø6.35	ø9.52*1	ø12.7
		ø9.52	ø9.52	
M series or S series	22 - 42	ø6.35	ø9.52	ø15.88
	50	ø6.35	ø12.7	
	60	ø6.35	ø15.88	
	71, 80	ø9.52	ø15.88	
P series	35 - 50	ø6.35	ø12.7	ø15.88
	60 - 100	ø9.52	ø15.88	

* If the pipe size of indoor unit is different, use a different-diameter joint.

*1 If the piping length after the first joint exceeds 30 m, use a pipe size of ø9.52 for the pipes of the system that exceeds 30 m.

2-branch joint	CMY-Y62-G-E
4-branch header	CMY-Y64-G-E
8-branch header	CMY-Y68-G-E

Different-diameter joint (optional parts) (Fig. 4-6)

Model name	Connected pipes diameter	Diameter A	Diameter B
	mm	mm	mm
MAC-A454JP	ø9.52 → ø12.7	ø9.52	ø12.7
MAC-A455JP	ø12.7 → ø9.52	ø12.7	ø9.52
MAC-A456JP	ø12.7 → ø15.88	ø12.7	ø15.88
PAC-493PI	ø6.35 → ø9.52	ø6.35	ø9.52
PAC-SG76RJ-E	ø9.52 → ø15.88	ø9.52	ø15.88

Different-diameter joint (optional parts) (Fig. 4-7)

Model name	Connected pipes diameter	Outside Diameter A	Inside Diameter B
	mm	mm	mm
PAC-SG78RJB-E	ø9.52 → ø12.7	ø9.52	ø12.7
PAC-SG79RJB-E	ø12.7 → ø9.52	ø12.7	ø9.52
PAC-SG80RJB-E	ø12.7 → ø15.88	ø12.7	ø15.88
PAC-SG77RJB-E	ø6.35 → ø9.52	ø6.35	ø9.52
PAC-SG76RJB-E	ø9.52 → ø15.88	ø9.52	ø15.88

2-branch pipe (Joint): Optional parts (According to the connection method, you can choose the favorite one.)

Model name	Connection method
MSDD-50AR-E	flare

Branch box

Model name	Number of connected units
PAC-MK3*BC	3-branches (Max. 3 units)
PAC-MK5*BC	5-branches (Max. 5 units)

Note: * = 0, 1, 2,

The PAC-MK31/32BC and PAC-MK51/52BC cannot be connected.

4. Installing the refrigerant piping

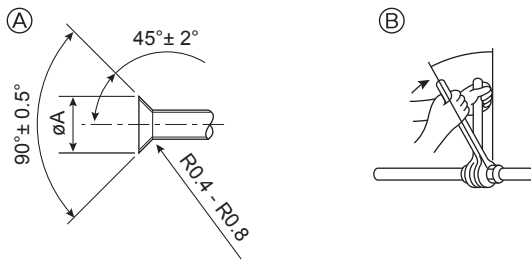

- Ⓐ Flare cutting dimensions
Ⓑ Flare nut tightening torque

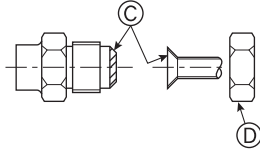

Fig. 4-8

Ⓐ (Fig. 4-8)

Copper pipe O.D. (mm)	Flare dimensions øA dimensions (mm)
ø6.35	8.7 - 9.1
ø9.52	12.8 - 13.2
ø12.7	16.2 - 16.6
ø15.88	19.3 - 19.7
ø19.05	23.6 - 24.0

Ⓑ (Fig. 4-8)

Copper pipe O.D. (mm)	Flare nut O.D. (mm)	Tightening torque (N·m)
ø6.35	17	14 - 18
ø6.35	22	34 - 42
ø9.52	22	34 - 42
ø12.7	26	49 - 61
ø12.7	29	68 - 82
ø15.88	29	68 - 82
ø15.88	36	100 - 120
ø19.05	36	100 - 120

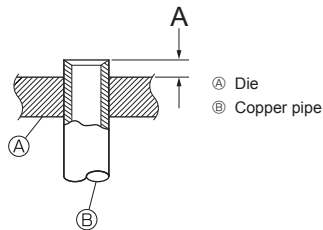

Fig. 4-9

4.2. Connecting pipes (Fig. 4-8)

Fig. 4-1, 4-2 is a sample of piping system.

- Conduct sufficient anti-condensation and insulation work to prevent water dripping from the refrigerant piping. (liquid pipe/gas pipe)
- Increase insulation depending on the environment where the refrigerant piping is installed, or condensation may occur on the surface of the insulation material. (Insulation material Heat-resistant temperature: 120 °C, Thickness: 15 mm or more)
 - * When the refrigerant piping is used in locations subject to high temperature and humidity such as in the attic, further addition of insulation may be required.
- To insulate the refrigerant piping, apply heat-resistant polyethylene foam between the indoor unit and insulation material as well as to the net between the insulation material filling all gaps. (Condensation forming on the piping may result in condensation in the room or burns when contacting the piping.)
- Be sure to separate thermal insulation for gas and liquid refrigerant pipes.
- The indoor parts of the drain pipe should be wrapped with polyethylene foam insulation materials (specific gravity of 0.03, thickness of 9 mm or more).
- Apply thin layer of refrigerant oil to pipe and joint seating surface before tightening flare nut. Ⓐ
- For connection, first align the center, then tighten the first 3 to 4 turns of flare nut by hand.
- Use 2 wrenches to tighten piping connections. Ⓑ
- Use leak detector or soapy water to check for gas leaks after connections are completed.
- Apply refrigerating machine oil over the entire flare seat surface. Ⓒ
- Use the flare nuts for the following pipe size. Ⓓ

		City Multi Indoor unit		Outdoor unit
		10-50	63-140	
Gas side	Pipe size (mm)	ø12.7	ø15.88	ø15.88
Liquid side	Pipe size (mm)	ø6.35*1	ø9.52	ø9.52

*1 If the farthest piping length after the first joint exceeds 30 m, use a pipe size of ø9.52.

- When bending the pipes, be careful not to break them. Bend radius of 100 mm to 150 mm is sufficient.
- Make sure the pipes do not contact the compressor. Abnormal noise or vibration may result.
- ① Pipes must be connected starting from the indoor unit. Flare nuts must be tightened with a torque wrench.
- ② Flare the liquid pipes and gas pipes and apply a thin layer of refrigeration oil (Applied on site).
- When usual pipe sealing is used, refer to Table 1 for flaring of R410A refrigerant pipes.

The size adjustment gauge can be used to confirm A measurements.

* To connect the CONNECTION KIT (PAC-LV11M-J), refer to the installation manual for the CONNECTION KIT.

Table 1 (Fig. 4-9)

Copper pipe O.D. (mm)	A (mm)	
	Flare tool for R410A	Flare tool for R22-R407C
	Clutch type	
ø6.35 (1/4")	0 - 0.5	1.0 - 1.5
ø9.52 (3/8")	0 - 0.5	1.0 - 1.5
ø12.7 (1/2")	0 - 0.5	1.0 - 1.5
ø15.88 (5/8")	0 - 0.5	1.0 - 1.5
ø19.05 (3/4")	0 - 0.5	1.0 - 1.5

4. Installing the refrigerant piping

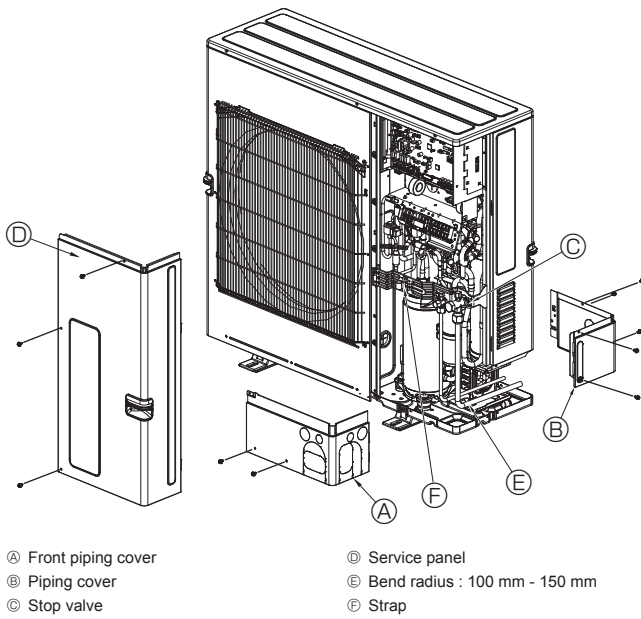

Fig. 4-10

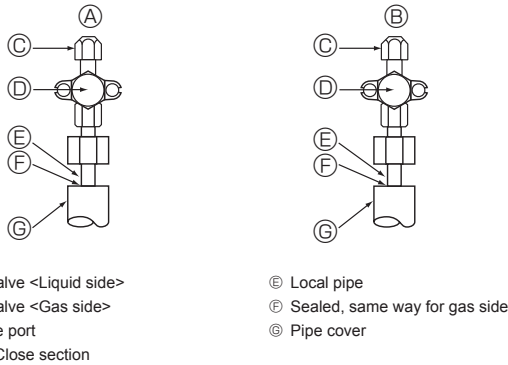

Fig. 4-11

4.3. Refrigerant piping (Fig. 4-10)

Remove the service panel ④ (three screws) and the front piping cover ① (two screws) and rear piping cover ② (five screws).

- ① Perform refrigerant piping connections for the indoor/outdoor unit when the outdoor unit's stop valve is completely closed.
- ② Vacuum-purge air from the indoor unit and the connection piping.
- ③ After connecting the refrigerant pipes, check the connected pipes and the indoor unit for gas leaks. (Refer to 4.4. Refrigerant pipe airtight testing method)
- ④ Vacuumize the refrigerant lines through the service port of the liquid and gas stop valves. This will completely connect the refrigerant lines of the indoor and outdoor units.
 - If the stop valves are left closed and the unit is operated, the compressor and control valves will be damaged.
 - Use a leak detector or soapy water to check for gas leaks at the pipe connection sections of the outdoor unit.
 - Do not use the refrigerant from the unit to purge air from the refrigerant lines.
 - After the valve work is completed, tighten the valve caps to the correct torque: 20 to 25 N·m (200 to 250 kgf·cm). Failure to replace and tighten the caps may result in refrigerant leakage. In addition, do not damage the insides of the valve caps as they act as a seal to prevent refrigerant leakage.
- ⑤ Use sealant to seal the ends of the thermal insulation around the pipe connection sections to prevent water from entering the thermal insulation.

4.4. Refrigerant pipe airtight testing method

- (1) Connect the testing tools.
 - Make sure the stop valves ① ② are closed and do not open them.
 - Add pressure to the refrigerant lines through the service port ③ of the liquid stop valve ① and the gas stop valve ②.
- (2) Do not add pressure to the specified pressure all at once; add pressure little by little.
 - ① Pressurize to 0.5 MPa (5 kgf/cm²G), wait five minutes, and make sure the pressure does not decrease.
 - ② Pressurize to 1.5 MPa (15 kgf/cm²G), wait five minutes, and make sure the pressure does not decrease.
 - ③ Pressurize to 4.15 MPa (41.5 kgf/cm²G) and measure the surrounding temperature and refrigerant pressure.
- (3) If the specified pressure holds for about one day and does not decrease, the pipes have passed the test and there are no leaks.
 - If the surrounding temperature changes by 1°C, the pressure will change by about 0.01 MPa (0.1 kgf/cm²G). Make the necessary corrections.
- (4) If the pressure decreases in steps (2) or (3), there is a gas leak. Look for the source of the gas leak.

4. Installing the refrigerant piping

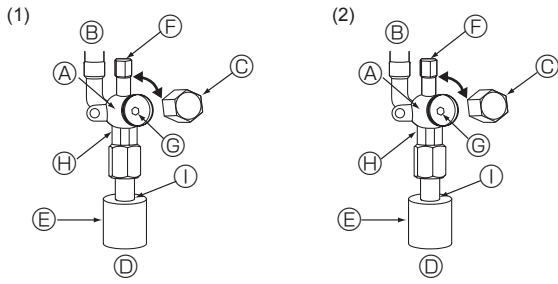

- Ⓐ Valve body
- Ⓑ Unit side
- Ⓒ Cap
- Ⓓ Local pipe side
- Ⓔ Pipe cover
- Ⓕ Service port
- Ⓖ Valve stem

- Ⓗ Double spanner section
(Do not apply a spanner other than to this section. Doing so would cause coolant leaks.)
- Ⓘ Seal section
(Seal the end of the heat insulation material at the pipe connection section with whatever seal material you have on hand so that water does not infiltrate the heat insulation material.)

Fig. 4-12

Fig. 4-13

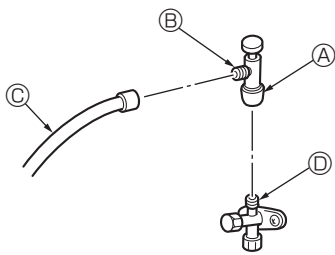

- * The figure to the left is an example only. The stop valve shape, service port position, etc., may vary according to the model.
- * Turn section Ⓐ only.
(Do not further tighten sections Ⓐ and Ⓑ together.)

- Ⓒ Charge hose
- Ⓔ Service port

Fig. 4-14

4.6. Additional refrigerant charge

Additional refrigerant charge

Refrigerant for the extended piping is not included in the outdoor unit when the unit is shipped from the factory. Therefore, charge each refrigerant piping system with additional refrigerant at the installation site. In addition, in order to carry out service, enter the size and length of each liquid pipe and additional refrigerant charge amounts in the spaces provided on the "Refrigerant amount" plate on the outdoor unit.

* When the unit is stopped, charge the unit with the additional refrigerant through the liquid stop valve after the pipe extensions and indoor units have been vacuumized.

When the unit is operating, add refrigerant to the gas check valve using a safety charger. Do not add liquid refrigerant directly to the check valve.

Calculation of additional refrigerant charge

- Calculate the additional charge using the liquid pipe size and length of the extended piping.
- Calculate the additional refrigerant charge using the procedure shown to the right, and charge with the additional refrigerant.
- For amounts less than 0.1 kg, round up the calculated additional refrigerant charge.
(For example, if the calculated charge is 32.92 kg, round up the charge to 33.0 kg.)

4.5. Stop valve opening method

The stop valve opening method varies according to the outdoor unit model. Use the appropriate method to open the stop valves.

(1) Gas side (Fig. 4-12)

- ① Remove the cap and turn the valve rod counterclockwise as far as it will go with the use of a 5 mm hexagonal wrench. Stop turning when it hits the stopper. (ø15.88: Approximately 13 revolutions)

- ② Make sure that the stop valve is open completely and rotate the cap back to its original position.

(2) Liquid side (Fig. 4-13)

- ① Remove the cap and turn the valve rod counterclockwise as far as it will go with the use of a 4 mm hexagonal wrench. Stop turning when it hits the stopper. (ø9.52: Approximately 10 revolutions)

- ② Make sure that the stop valve is open completely, push in the handle and rotate the cap back to its original position.

Refrigerant pipes are protectively wrapped

- The pipes can be protectively wrapped up to a diameter of ø90 before or after connecting the pipes. Cut out the knockout in the pipe cover following the groove and wrap the pipes.

Pipe inlet gap

- Use putty or sealant to seal the pipe inlet around the pipes so that no gaps remain. (If the gaps are not closed, noise may be emitted or water and dust will enter the unit and breakdown may result.)

⚠ Warning:

When opening or closing the valve below freezing temperatures, refrigerant may spurt out from the gap between the valve stem and the valve body, resulting in injuries.

When installing the unit, securely connect the refrigerant pipes before starting the compressor.

Precautions when using the charge valve (Fig. 4-14)

Do not tighten the service port too much when installing it, otherwise, the valve core could be deformed and become loose, causing a gas leak.

After positioning section Ⓑ in the desired direction, turn section Ⓐ only and tighten it. Do not further tighten sections Ⓐ and Ⓑ together after tightening section Ⓐ.

<Additional Charge>

Calculation of refrigerant charge

Pipe size		Pipe size		Total capacity of connected indoor units	Amount for the indoor units
Liquid pipe		Liquid pipe		- 8.0 kW	1.5 kg
ø6.35	+	ø9.52	+	8.1 - 16.0 kW	2.5 kg
(m) × 19.0 (g/m)		(m) × 50.0 (g/m)		16.1 kW -	3.0 kg

Included refrigerant amount when shipped from the factory

Included refrigerant amount
3.5 kg

Calculation example (Please see the lower half of Fig. 4-1.)

Outdoor model : SP140	A : ø9.52 [3/8"]/ø15.88 [5/8"] : 30 m	} For these piping lengths
1: P100 (11.2 kW)	a : ø9.52 [3/8"]/ø15.88 [5/8"] : 15 m	
2: P40 (4.5 kW)	b : ø6.35 [1/4"]/ø12.7 [1/2"] : 10 m	

The total length of each pipe size is as follows:

ø9.52 [3/8"]/ø15.88 [5/8"] : A = 30 m

ø9.52 [3/8"]/ø15.88 [5/8"] : a = 15 m

ø6.35 [1/4"]/ø12.7 [1/2"] : b = 10 m

The total capacity of connected indoor unit is as follows:

11.2 + 4.5 = 15.7

Therefore, the additional charge is as follows:

$$= 10 \times \frac{19.0}{1000} + (30 + 15) \times \frac{50.0}{1000} + 2.5$$

$$= 5.0 \text{ kg (rounded up)}$$

5. Drainage piping work

Outdoor unit drainage pipe connection

When drain piping is necessary, use the drain socket or the drain pan (option).

Drain socket	PAC-SG61DS-E
Drain pan	PAC-SH97DP-E

6. Electrical work

6.1. Caution

- ① Follow ordinance of your governmental organization for technical standard related to electrical equipment, wiring regulations and guidance of each electric power company.
- ② Wiring for control (hereinafter referred to as transmission line) shall be (5 cm or more) apart from power source wiring so that it is not influenced by electric noise from power source wiring. (Do not insert transmission line and power source wire in the same conduit.)
- ③ Be sure to provide designated grounding work to outdoor unit.
- ④ Give some allowance to wiring for electrical part box of indoor and outdoor units, because the box is sometimes removed at the time of service work.
- ⑤ Never connect the main power source to terminal block of transmission line. If connected, electrical parts will be burnt out.
- ⑥ Use 2-core shield cable for transmission line. If transmission lines of different systems are wired with the same multiple-core cable, the resultant poor transmitting and receiving will cause erroneous operations.
- ⑦ Only the transmission line specified should be connected to the terminal block for outdoor unit transmission.
(Transmission line to be connected with indoor unit : Terminal block TB3 for transmission line, Other : Terminal block TB7 for centralized control)
Erroneous connection does not allow the system to operate.

- ⑧ In case to connect with the upper class controller or to conduct group operation in different refrigerant systems, the control line for transmission is required between the outdoor units each other.
Connect this control line between the terminal blocks for centralized control. (2-wire line with no polarity)
- ⑨ When conducting group operation in different refrigerant systems without connecting to the upper class controller, replace the insertion of the short circuit connector from CN41 of one outdoor unit to CN40.
- ⑩ Group is set by operating the remote controller.
- ⑪ When connecting the CONNECTION KIT (PAC-LV11M-J) and an M-series indoor unit, refer to the installation manual for the CONNECTION KIT.
- ⑫ When connecting a branch box, be sure to turn on the indoor units and the branch box before turning on the outdoor unit.
- ⑬ Use the strap on the unit to sufficiently fasten the cables connected to the terminal blocks. In addition, make sure that the fastened cables and the strap do not interfere with the panels.

<PUMY-SP-VKMD>

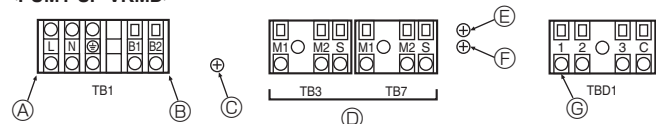

<PUMY-SP-YKMD>

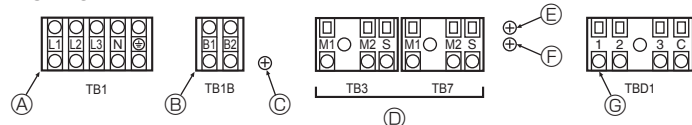

- Ⓐ Power source
- Ⓑ Power supply for branch box
- Ⓒ Screw on the electrical component box for ground connection (TB1/TB1B)
- Ⓓ Transmission line
- Ⓔ Screw on the electrical component box for ground connection (TB3)
- Ⓕ Screw on the electrical component box for ground connection (TB7)
- Ⓖ DRED signal input

Fig. 6-1

6.2. Control box and connecting position of wiring (Fig. 6-1)

1. Connect the wiring between the outdoor unit and the indoor unit or branch box to the transmission terminal block (TB3) of the outdoor unit.
Connect the wiring between the outdoor unit and the centralized control system to the transmission terminal block (TB7) of the outdoor unit.
When using shielded wiring, connect the ground of the shielded wiring to the shield terminal (S) of the terminal block (TB3) or (TB7).
If the connection of the outdoor unit's transmission power supply connector has been changed from CN41 to CN42, connect the shield terminal (S) of the terminal block (TB7) to the screw (Ⓔ) using the included lead wire.
* The shield (S) terminal of the transmission terminal block (TB3) is connected to the ground (Ⓔ) when the unit is shipped from the factory.
2. The terminal (B1) and (B2) on the terminal block (TB1B or TB1) is for supplying power to the branch box (220 – 240 VAC, max 6 A).
3. The terminal block (TBD1) is for the input of the DRED signals (12 VDC, 1 mA).
4. Remove the knock-out pieces from the piping cover, pass the power supply and transmission wires through the appropriate knock-out holes, and connect the wires to the terminal block.
5. Fix power source wiring to the terminal block by using buffer bushing for tensile force (PG connection or the like).

⚠ Caution:

Never connect the transmission line for the indoor unit or the centralized control system transmission line to this terminal block (TB1B/TBD1). If the transmission lines are connected, the indoor unit or centralized control could be damaged.

6. Electrical work

6.3. Wiring transmission cables

① Types of control cables

1. Wiring transmission cables

Types of transmission cables	Shielding wire CVVS, CPEVS or MVVS
Cable diameter	More than 1.25 mm ²
Maximum wiring length	Within 200 m

2. M-NET Remote control cables

Types of remote control cables	Shielding wire CVVS, CPEVS or MVVS
Cable diameter	0.5 to 1.25 mm ² (0.75 to 1.25 mm ²)*
Remarks	When 10 m is exceeded, use cable with the same specifications as transmission line wiring cables.

* Connected with simple remote controller.

3. MA Remote control cable

Type of remote control cable	Sheathed 2-core cable (unshielded) CVV
Cable diameter	0.3 to 1.25 mm ² (0.75 to 1.25 mm ²)*
Remarks	Within 200 m

* Connected with simple remote controller.

② Wiring examples

• Controller name, symbol and allowable number of controllers.

Name	Symbol	Allowable number of controllers			
Outdoor unit controller	OC	-			
Indoor unit controller	CITY MULTI series	M-IC	PUMY-SP80	1 to 9 units per 1 OC *1	
			PUMY-SP112	1 to 12 units per 1 OC *1	
			PUMY-SP125		
	M, S, P series	A-IC		PUMY-SP140	2 to 5 units per 1 OC *1
				PUMY-SP112	2 to 7 units per 1 OC *1
				PUMY-SP125	2 to 8 units per 1 OC *1
	PUMY-SP140				
Branch box	BC	0 to 2 units per 1 OC *1			
Remote controller	M-NET	M-NET RC *2	Maximum of 12 controllers for 1 OC (Can not be connected if Branch box is used.) *1		
	MA	MA-RC	Maximum of 2 per group		
	Wireless	WL-RC	-		

Note:

*1. The number of connectable units may be limited by some conditions such as an indoor unit's capacity or each unit's equivalent power consumption.

*2. Don't use the Lossnay controller (PZ-61DR-E, PZ-43SMF-E, PZ-52SF-E, PZ-60DR-E).

Example of a group operation system with multiple outdoor units (Shielding wires and address setting are necessary.)

<Examples of Transmission Cable Wiring>

■ Refer to Fig. 6-6 from Fig. 6-2.

<Wiring Method and Address Settings: without Branch box system>

- Always use shielded wire when making connections between the outdoor unit (OC) and the indoor unit (M-IC).
- Use feed wiring to connect terminals M1 and M2 and the ground terminal on the transmission cable terminal block (TB3) of each outdoor unit (OC) to terminals M1, M2 and terminal S on the transmission cable terminal block of the indoor unit (M-IC).
- Connect terminals 1 (M1) and 2 (M2) on the transmission cable terminal block of the indoor unit (M-IC) that has the most recent address within the same group to the terminal block on the remote controller (M-NET RC).
- Connect together terminals M1, M2 and terminal S on the terminal block for centralized control (TB7) for the outdoor unit (OC).
- The jumper connector CN41 on the control panel does not change.
- Connect shield ground of the indoor units transmission line to the shield (S) terminal of (TB3).
Connect shield ground of the line between outdoor units and the centralized control system transmission line to the shield (S) terminal of (TB7).
- Set the address setting switch as follows.

Unit	Range	Setting Method
M-IC (Main)	01 to 50	Use the most recent address within the same group of indoor units
M-IC (Sub)	01 to 50	Use an address, other than that of the M-IC (Main) from among the units within the same group of indoor units. This must be in sequence with the M-IC (Main)
Outdoor unit	51 to 100	Use the most recent address of all the indoor units plus 50 * The address automatically becomes "100" if it is set as "01 - 50".
M-NET RC (Main) *1	101 to 150	Set at an M-IC (Main) address within the same group plus 100
M-NET RC (Sub) *1	151 to 200	Set at an M-IC (Main) address within the same group plus 150
MA RC	—	Unnecessary address setting (Necessary main/sub setting)

*1 An M-NET remote controller cannot be connected to a system that contains a branch box.

- The group setting operations among the multiple indoor units is done by the remote controller (M-NET RC) after the electrical power has been turned on.

<Wiring Method and Address Setting: include Branch box system>

Please refer to the Branch box Installation Manual.

6. Electrical work

■ M-NET Remote Controller

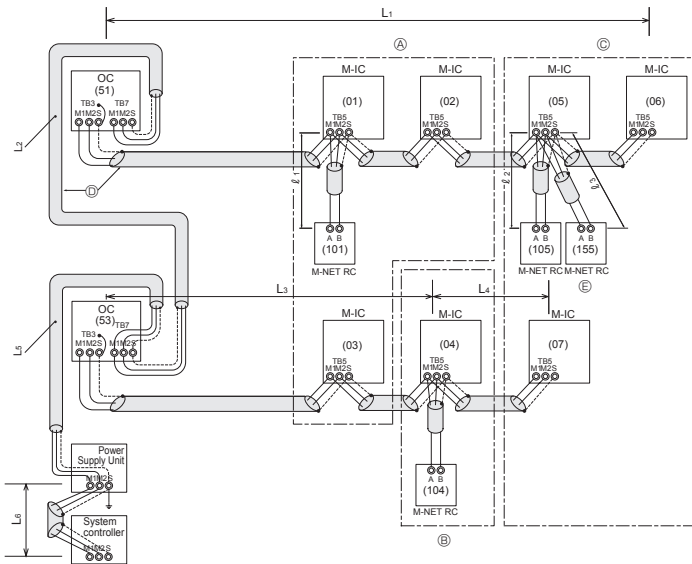

- (A) : Group 1
- (B) : Group 2
- (C) : Group 3
- (D) : Shielded Wire
- (E) : Sub Remote Controller
- () : Address

<Permissible Lengths>

- Max length via outdoor units: $L_1+L_2+L_3+L_4$, $L_3+L_4+L_5+L_6$ and $L_1+L_2+L_5+L_6 \leq 500$ m (1.25 mm² or more)
 - Max transmission cable length: L_1 , L_3+L_4 , L_2+L_5 and $L_6 \leq 200$ m (1.25 mm² or more)
 - Remote controller cable length: l_1 , $l_2 + l_3 \leq 10$ m (0.5 to 1.25 mm²)
- If the length exceeds 10 m, use a 1.25 mm² shielded wire. The section of the cable that exceeds 10 m must be included in the longest length via outdoor units and longest transmission cable length.

Fig. 6-2

■ MA Remote Controller

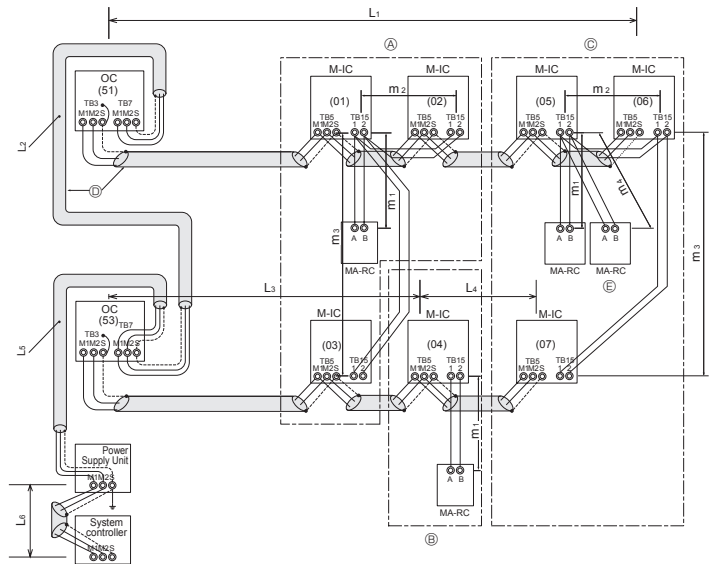

<Permissible Lengths>

- Max length via outdoor unit (M-NET cable): $L_1+L_2+L_3+L_4$ and $L_1+L_2+L_5+L_6 \leq 500$ m (1.25 mm² or more)
- Max transmission cable length (M-NET cable): L_1 , L_3+L_4 , L_2+L_5 and $L_6 \leq 200$ m (1.25 mm² or more)
- Remote controller cable length: m_1 , $m_1+m_2+m_3$ and $m_1+m_2+m_3+m_4 \leq 200$ m (0.3 to 1.25 mm²)

Fig. 6-3

<Example of Transmission Cable Wiring: Connecting with Branch box>

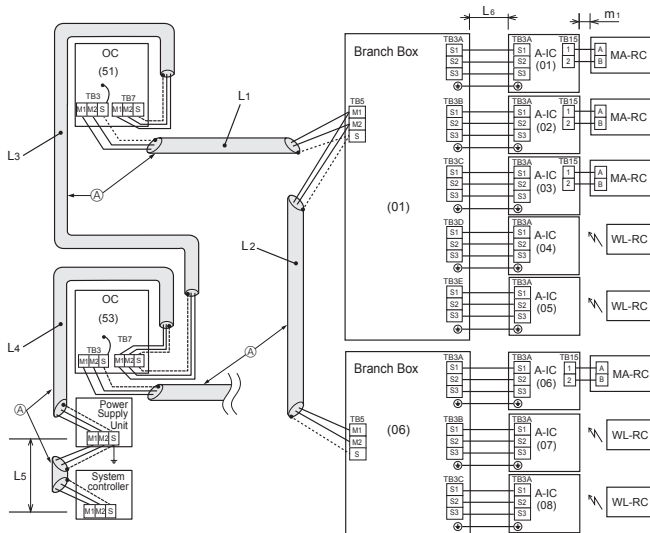

- (A) : Shielded wire
- () : Address example

<Permissible Lengths>

- Max length via outdoor units (M-NET cable): $L_1+L_2+L_3+L_4+L_6 \leq 500$ m (1.25 mm² or more)
- Max transmission cable length (M-NET cable): $L_1+L_2+L_3+L_4+L_6 \leq 200$ m (1.25 mm² or more)
- Max transmission cable length (A-control cable): $L_6 \leq 25$ m (1.5 mm²)
- Remote controller cable length: $m_1 \leq 200$ m (0.3 to 1.25 mm²)

Fig. 6-4

<Example of Transmission Cable Wiring: Mixing system>

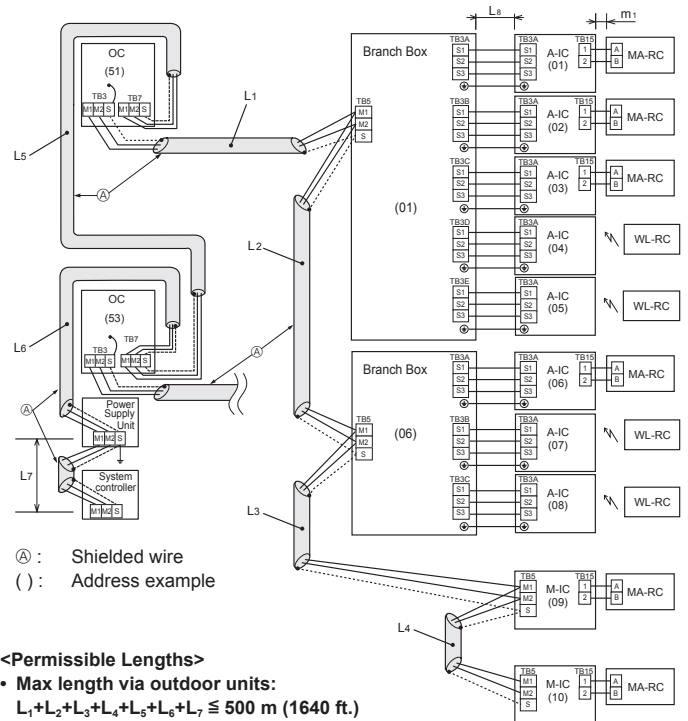

- (A) : Shielded wire
- () : Address example

<Permissible Lengths>

- Max length via outdoor units: $L_1+L_2+L_3+L_4+L_5+L_6+L_7 \leq 500$ m (1640 ft.) (1.25 mm² or more)
- Max transmission cable length: $L_1+L_2+L_3+L_4$, L_5+L_6 , $L_7 \leq 200$ m (656 ft.) (1.25 mm² or more)
- Max transmission cable length (M-NET cable): $L_8 \leq 25$ m (1.5 mm²)
- Remote controller cable length: $m_1 \leq 200$ m (0.3 to 1.25 mm²)

Fig. 6-5

6. Electrical work

System chart <mixed system with branch boxes and City Multi indoor units>

[1] Basic system

OC: Outdoor unit
 BC: Branch box
 M-IC: M-NET control Indoor unit (City Multi indoor unit)
 A-IC: A-control indoor unit (M, S, P series indoor unit)
 MA-RC: MA remote controller
 M-NET RC: M-NET remote controller
 WL-RC: Wireless remote controller

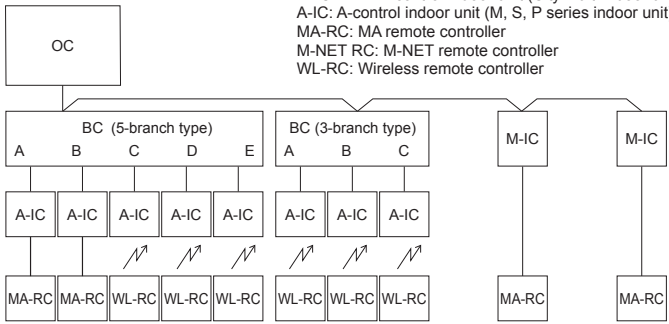

[2] Incorrect systems

① Group operation by MA remote controller

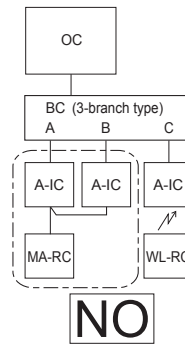

② Group operation between different refrigerant systems

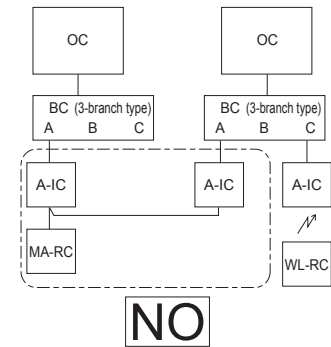

③ Group operation between A-control system and M-NET control system

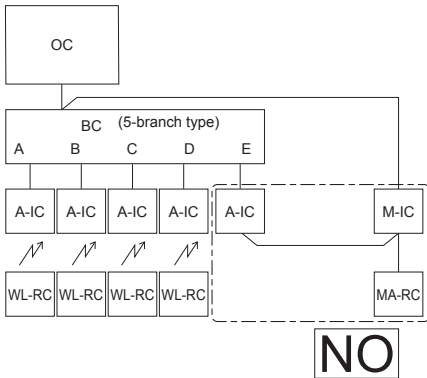

④ M-NET remote controller connection to a system that contains a branch box

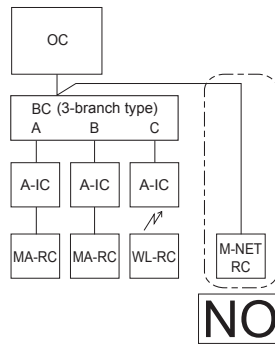

- ① Plural indoor units cannot be operated by a MA remote controller.
- ② Different refrigerant systems cannot be connected together.
- ③ Different types control systems (A-IC/M-IC) cannot be connected together.
- ④ An M-NET remote controller cannot be connected to a system that contains a branch box.

Fig. 6-6

6.4. Wiring of main power supply and equipment capacity

Schematic Drawing of Wiring (Example) (Fig. 6-7)

■ PUMY-SP-VKMD

~/N 220-230-240 V 50 Hz
 ~/N 220 V 60 Hz

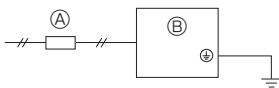

■ PUMY-SP-YKMD

3N~ 380-400-415 V 50 Hz
 3N~ 380 V 60 Hz

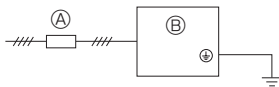

~/N 220-230-240 V 50 Hz
 ~/N 220 V 60 Hz

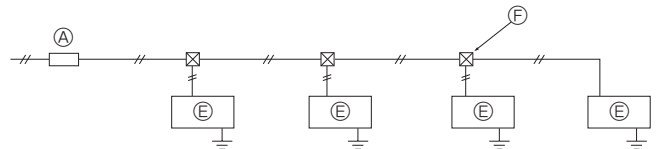

- Ⓐ Switch (Breakers for Wiring and Current Leakage)
- Ⓑ Outdoor Unit
- Ⓒ Branch box
- Ⓓ A-control indoor unit (M, S, P series indoor unit)
- Ⓔ M-NET control Indoor unit (City Multi indoor unit)
- Ⓕ Pull Box

Fig. 6-7

6. Electrical work

Schematic Drawing of Wiring Connection with Branch Box (Example) (Fig. 6-8)

<When power is supplied from the outdoor unit>

■ PUMY-SP-VKMD

~N 220-230-240 V 50 Hz
~N 220 V 60 Hz

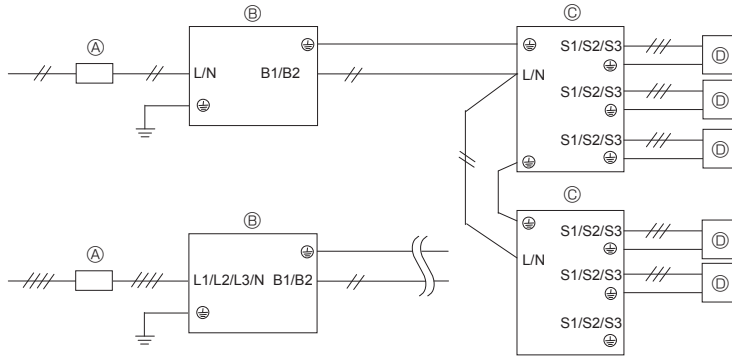

■ PUMY-SP-YKMD

3N~380-400-415 V 50 Hz
3N~380 V 60 Hz

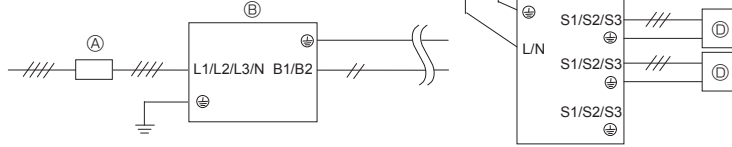

<When power is supplied separately>

■ PUMY-SP-VKMD

~N 220-230-240 V 50 Hz
~N 220 V 60 Hz

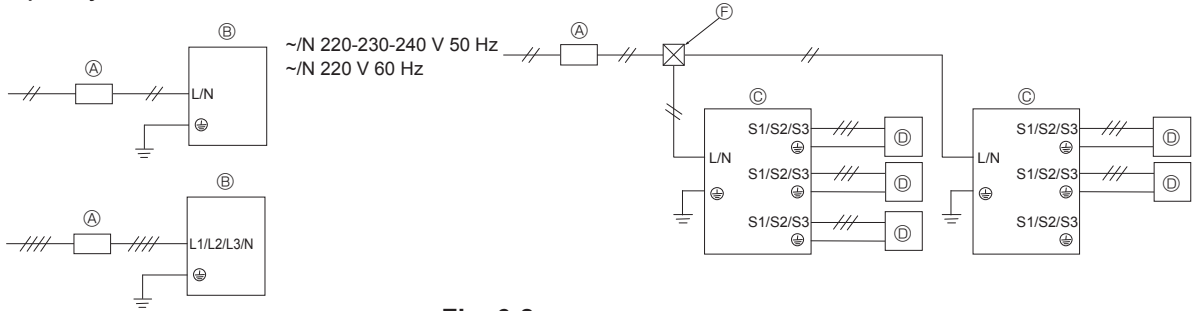

■ PUMY-SP-YKMD

3N~380-400-415 V 50 Hz
3N~380 V 60 Hz



Fig. 6-8

Schematic Drawing of Wiring: Mixing system (Fig. 6-9)

<When power is supplied from the outdoor unit>

■ PUMY-SP-VKMD

~N 220-230-240 V 50 Hz
~N 220 V 60 Hz

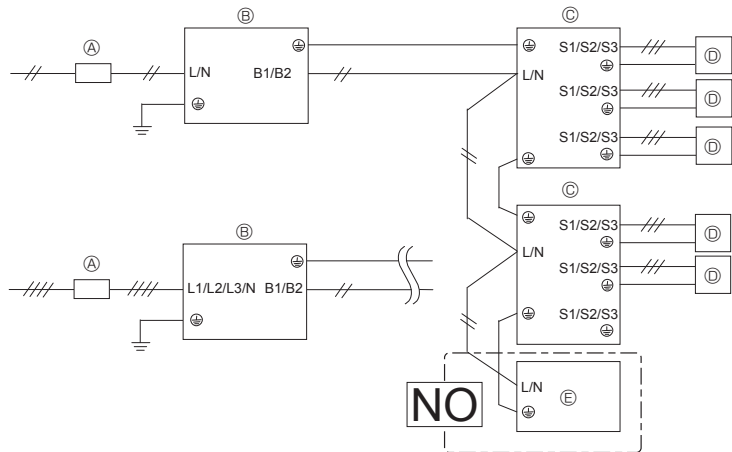

■ PUMY-SP-YKMD

3N~380-400-415 V 50 Hz
3N~380 V 60 Hz

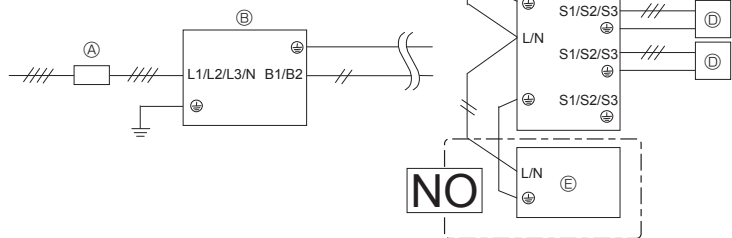

* The M-NET Control Indoor unit cannot receive power supplied from an outdoor unit, so provide it with power separately.

<When power is supplied separately>

■ PUMY-SP-VKMD

~N 220-230-240 V 50 Hz
~N 220 V 60 Hz

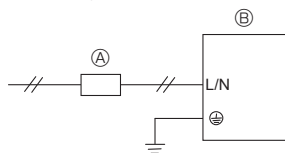

■ PUMY-SP-YKMD

3N~380-400-415 V 50 Hz
3N~380 V 60 Hz

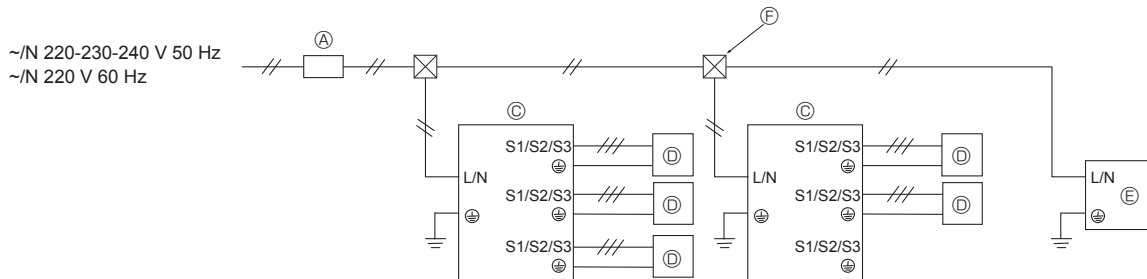
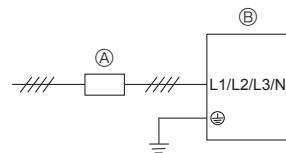

Note: Reactor BOX (Optional parts) for Branch box.

When the product is used for a purpose other than as professional equipment, the Reactor BOX may be necessary.

Outdoor unit	Branch box power supply method	
	Power supply from outdoor unit	Separate power supply
1-phase power supply	Unnecessary	Necessary
3-phase power supply	Necessary	Necessary

Fig. 6-9

6. Electrical work

Thickness of Wire for Main Power Supply and On/Off Capacities

Model	Power supply	Minimum Wire Thickness (mm ²)			Breaker for Wiring *1	Breaker for Current Leakage	
			Main Cable	Ground			
Outdoor unit	~ /N 220-230-240 V 50 Hz ~ /N 220 V 60 Hz	When power is supplied separately	SP80	2.5	2.5	25 A	25 A 30 mA 0.1 sec. or less
			SP112/125/140	6.0	6.0	32 A	32 A 30 mA 0.1 sec. or less
		When power is supplied from the outdoor unit		6.0	6.0	40 A	40 A 30 mA 0.1 sec. or less
	3N~ 380-400-415 V 50 Hz 3N~ 380 V 60 Hz*2	When power is supplied separately		2.5	2.5	16 A	16 A 30 mA 0.1 sec. or less
		When power is supplied from the outdoor unit		4.0	4.0	25 A	25 A 30 mA 0.1 sec. or less
Indoor unit / Branch box	~ /N 220-230-240 V 50 Hz ~ /N 220 V 60 Hz	Refer to the following indoor unit or branch box wiring and breaker capacity calculation.					

*1. A breaker with at least 3.0 mm contact separation in each poles shall be provided. Use earth leakage breaker (NV).

*2. In multi-phase appliances, the colour of the neutral conductor of the supply cord, if any, shall be blue.

<Indoor unit> <When power is supplied to indoor unit and outdoor unit separately>

Total operating current of the indoor unit	Minimum wire thickness (mm ²)			Ground-fault interrupter *1	Local switch (A)		Breaker for wiring (NFB)
	Main Cable	Branch	Ground		Capacity	Fuse	
F0 = 16 A or less *2	1.5	1.5	1.5	20 A current sensitivity *3	16	16	20
F0 = 25 A or less *2	2.5	2.5	2.5	30 A current sensitivity *3	25	25	30
F0 = 32 A or less *2	4.0	4.0	4.0	40 A current sensitivity *3	32	32	40

Apply to IEC61000-3-3 about max. permissive system impedance.

*1 The Ground-fault interrupter should support inverter circuit.

The Ground-fault interrupter should combine using of local switch or wiring breaker.

*2 Please take the larger of F1 or F2 as the value for F0.

F1 = Total operating maximum current of the indoor units × 1.2

F2 = {V1 × (Quantity of Type 1)/C} + {V1 × (Quantity of Type 2)/C} + ... + {V1 × (Quantity of Type 16)/C}

Connect to Branch box (PAC-MK·BC)

Indoor unit	V1	V2
Type 1 PEAD-RP·JAA, PEAD-M·JAA(D)	26.9	2.4
Type 2 SEZ-KD·VA(L), PLA-RP·BA, PCA-RP·KAQ, PLA-M·EA-A, PCA-M·KA	19.8	
Type 3 SLZ-KF·VA3	17.1	
Type 4 MLZ-KP·VF-A	9.9	
Type 5 MFZ-KJ·VE-A1, MSZ-AP·VGD-A1, MSZ-LN·VG	7.4	
Type 6 MSZ-GE·VAD-A1, MSZ-FH·VE-A1, MSZ-EF·VE2-A1	6.8	
Type 7 SLZ-KA·VA(L)	3.5	
Type 8 Branch box (PAC-MK·BC)	5.1	

Connect to Connection kit (PAC-LV11M)

Indoor unit	V1	V2
Type 9 MSZ-AP·VGD, MSZ-LN·VG	7.4	2.4
Type 10 MSZ-GE·VAD, MSZ-EF·VE2, MSZ-FH·VE	6.8	
Type 11 Connection kit (PAC-LV11M)	3.5	

Indoor unit	V1	V2
Type 12 PEFY-P·VMA(L)-E, PEFY-P·VMA3-E	38.0	1.6
Type 13 PMFY-P·VBM-E, PLFY-P·VBM-E, PLFY-P·VFM-E1, PEFY-P·VMS1(L)-E, PCFY-P·VKM-E, PKFY-P·VHM-E, PKFY-P·VKM-E, PFFY-P·VKM-E2, PFFY-P·VLRMM-E, PKFY-P·VLM-E, PLFY-P·VEM	19.8	2.4
Type 14 PLFY-P·VCM-E2	9.9	
Type 15 PKFY-P·VBM-E	3.5	
Type 16 PLFY-P·VLMD-E, PEFY-P·VMH(S)-E, PEFY-P·VMR-E-L/R, PEFY-P·VMH-E-F, PFFY-P·VLEM-E, PFFY-P·VLRM-E, GUF-RD(H)4	0	0

C : Multiple of tripping current at tripping time 0.01s

Please pick up "C" from the tripping characteristic of the breaker.

6. Electrical work

<Example of "F2" calculation>

Condition PEFY-P-VMS1-E × 4 + PEFY-P-VMA-E × 1, C = 8 (refer to right sample chart)

$$F2 = 19.8 \times 4/8 + 38 \times 1/8 = 14.65$$

*3 Current sensitivity is calculated using the following formula.

$$G1 = \{V2 \times (\text{Quantity of Type1})\} + \{V2 \times (\text{Quantity of Type2})\} + \dots + \{V2 \times (\text{Quantity of Type16})\} + \{V3 \times (\text{Wire length[km]})\}$$

G1	Current sensitivity
30 or less	30 mA 0.1 sec or less
100 or less	100 mA 0.1 sec or less

Wire thickness	V3
1.5 mm ²	48
2.5 mm ²	56
4.0 mm ²	66

Sample chart

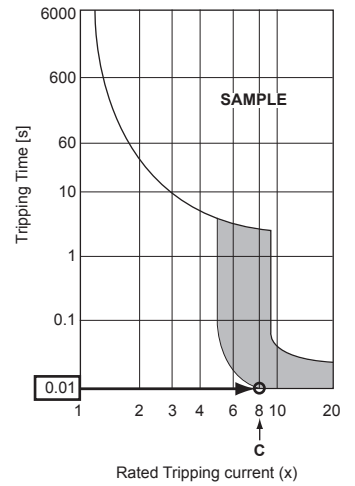

1. Use a separate power supply for the outdoor unit and indoor unit.
2. Bear in mind ambient conditions (ambient temperature, direct sunlight, rain water, etc.) when proceeding with the wiring and connections.
3. The wire size is the minimum value for metal conduit wiring. The power cord size should be 1 rank thicker consideration of voltage drops. Make sure the power-supply voltage does not drop more than 10%.
4. Specific wiring requirements should adhere to the wiring regulations of the region.
5. Power supply cords of parts of appliances for outdoor use shall not be lighter than polychloroprene sheathed flexible cord (design 60245 IEC57). For example, use wiring such as YZW.
6. Install an earth longer than other cables.

⚠ Warning:

- Be sure to use specified wires to connect so that no external force is imparted to terminal connections. If connections are not fixed firmly, it may cause heating or fire.
- Be sure to use the appropriate type of overcurrent protection switch. Note that generated overcurrent may include some amount of direct current.
- Be sure to attach the terminal block covers/panel of the outdoor unit securely. If it is not attached correctly, it could result in a fire or an electric shock due to dust, water, etc.

⚠ Caution:

- Be careful not to make mis-wiring.
- Firmly tighten the terminal screws to prevent them from loosening.
- After tightening, pull the wires lightly to confirm that they not move.
- If the connecting wire is incorrectly connected to the terminal block, the unit does not operate normally.
- Some installation site may require attachment of an earth leakage breaker. If no earth leakage breaker is installed, it may cause an electric shock.
- Do not use anything other than breaker and fuse with correct capacity. Using fuse and wire or copper wire with too large capacity may cause a malfunction of unit or fire.

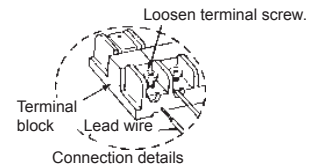

IMPORTANT

Make sure that the current leakage breaker is one compatible with higher harmonics. Always use a current leakage breaker that is compatible with higher harmonics as this unit is equipped with an inverter. The use of an inadequate breaker can cause the incorrect operation of inverter.

Never splice the power cable or the indoor-outdoor-branch box connection cable, otherwise it may result in a smoke, a fire or communication failure.

⚠ Warning:

- Please turn off the main power supply when servicing. And do not touch the B1, B2 terminals when the power is energized. If isolator should be used between outdoor unit and branch box/indoor unit and branch box, please use 2-pole type. (Please refer to figure below.)

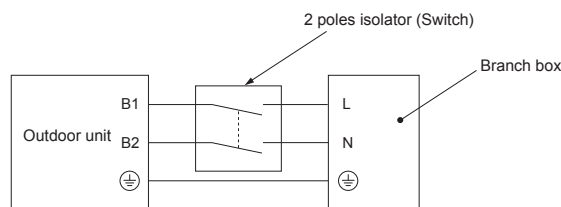

⚠ Caution:







After using the isolator, be sure to turn off and on the main power supply to reset the system. Otherwise, the outdoor unit may not be able to detect the branch box(es) or indoor units.

Be sure to connect the outdoor-branch box/indoor-branch box connecting cables directly to the units (no intermediate connections). Intermediate connections can lead to communication errors if water enters the cables and causes insufficient insulation to ground or a poor electrical contact at the intermediate connection point. (If an intermediate connection is necessary, be sure to take measures to prevent water from entering the cables.)

6. Electrical work

6.5. Address setting

Switch address setting

	Outdoor	Branch Box				M, S, P series Indoor	CITY MULTI series Indoor																																																															
		Address		Connection Setting																																																																		
Switch	 tens digit  ones digit SWU2 SWU1	 tens digit  ones digit SW12 SW11	<table border="1"> <tr> <th>A</th> <th>B</th> <th>C</th> <th>D</th> <th>E</th> <th>-</th> </tr> <tr> <td>1</td> <td>2</td> <td>3</td> <td>4</td> <td>5</td> <td>6</td> </tr> </table> SW1	A	B	C	D	E	-	1	2	3	4	5	6	ON: Indoor connect OFF: No connection (SW1-6 not use)	None	 tens digit  ones digit SW12 SW11																																																				
A	B	C	D	E	-																																																																	
1	2	3	4	5	6																																																																	
Range	51 - 100	1 - 50		-		-	1 - 50																																																															
Setting	CITY MULTI series Indoor or Branch Box address +50	<ul style="list-style-type: none"> According to the set address (for example, 01), the addresses for the connected indoor units are set sequentially (for example, 02, 03, 04, and 05). <table border="1"> <tr> <th>SW1</th> <th>1</th> <th>2</th> <th>3</th> <th>4</th> <th>5</th> <th></th> </tr> <tr> <td></td> <td>ON</td> <td>ON</td> <td>ON</td> <td>ON</td> <td>ON</td> <td></td> </tr> <tr> <th>Port</th> <th>A</th> <th>B</th> <th>C</th> <th>D</th> <th>E</th> <th></th> </tr> <tr> <td>Address</td> <td>01</td> <td></td> <td></td> <td></td> <td></td> <td>(SW11, 12)</td> </tr> <tr> <td></td> <td></td> <td>02</td> <td>03</td> <td>04</td> <td>05</td> <td>(sequential numbers)</td> </tr> </table>		SW1	1	2	3	4	5			ON	ON	ON	ON	ON		Port	A	B	C	D	E		Address	01					(SW11, 12)			02	03	04	05	(sequential numbers)	<ul style="list-style-type: none"> Specify whether indoor units are connected to each port (A, B, C, D, and E). <table border="1"> <tr> <th>SW1</th> <th>1</th> <th>2</th> <th>3</th> <th>4</th> <th>5</th> <th>(6)</th> </tr> <tr> <td></td> <td></td> <td></td> <td></td> <td></td> <td></td> <td></td> </tr> <tr> <th>Port</th> <th>A</th> <th>B</th> <th>C</th> <th>D</th> <th>E</th> <th>not use</th> </tr> <tr> <td></td> <td></td> <td></td> <td></td> <td></td> <td></td> <td></td> </tr> </table> Indoor units are connected ON Indoor units are not connected OFF		SW1	1	2	3	4	5	(6)								Port	A	B	C	D	E	not use								There are no address settings for the indoor units.	-
SW1	1	2	3	4	5																																																																	
	ON	ON	ON	ON	ON																																																																	
Port	A	B	C	D	E																																																																	
Address	01					(SW11, 12)																																																																
		02	03	04	05	(sequential numbers)																																																																
SW1	1	2	3	4	5	(6)																																																																
Port	A	B	C	D	E	not use																																																																

Note: 1. Branch box address

When setting the address, use a number within the range 1–50.

Ex. The set address is (47) and there are 5 indoor units (A, B, C, D, and E).

If A: (47), B: (48), C: (49), D: (50), and E: (51), E is incorrect because it exceeds 50.

Ex1. Outdoor + Branch <1> (M, S, P series Indoor A, B, C, D, E) + Branch <2> (M, S, P series Indoor A, B, C)

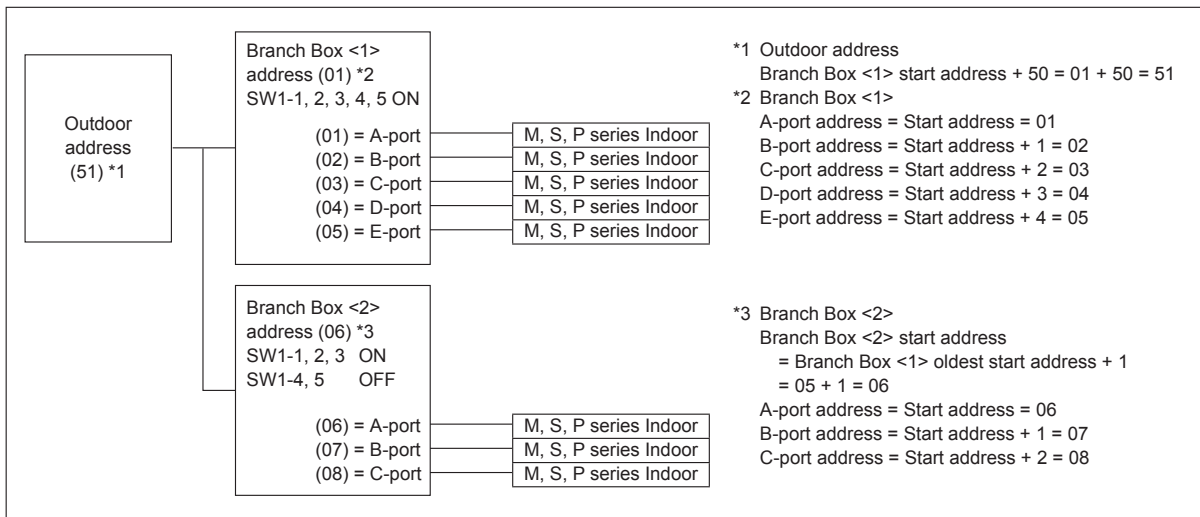

Ex2. Outdoor + Branch <1> (M, S, P series Indoor A, C, E) + Branch <2> (M, S, P series Indoor A, C, E)

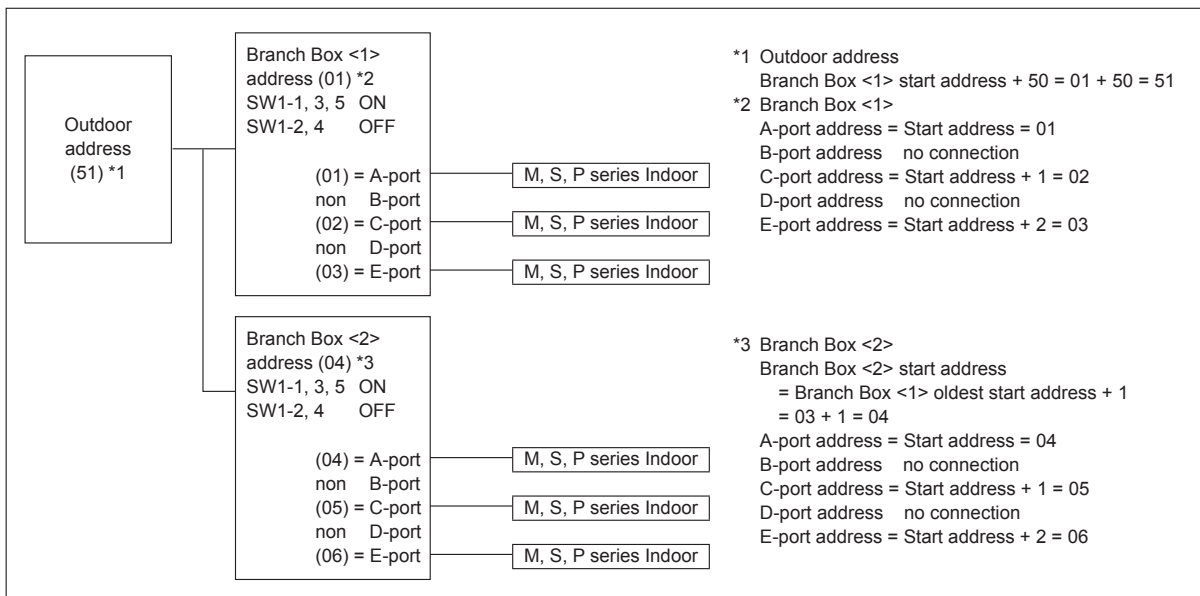

6. Electrical work

Ex3. Outdoor + Branch <1> (M, S, P series Indoor A, B, C, D, E) + Branch <2> (M, S, P series Indoor A, B, C) + CITY MULTI series Indoor <1> + CITY MULTI series Indoor <2>

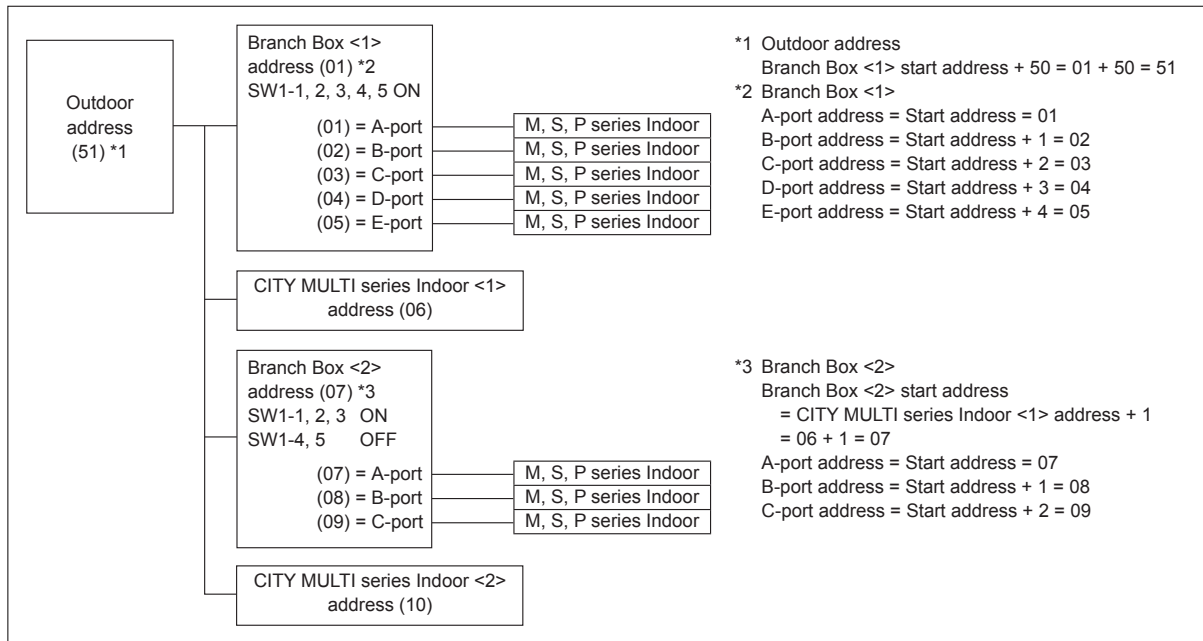

7. Test run

7.1. Before test run

- ▶ After completing installation and the wiring and piping of the indoor and outdoor units, check for refrigerant leakage, looseness in the power supply or control wiring, wrong polarity, and no disconnection of one phase in the supply.
 - ▶ Use a 500-volt M-ohm tester to check that the resistance between the power supply terminals and ground is at least 1 MΩ.
 - ▶ Do not carry out this test on the control wiring (low voltage circuit) terminals.
- ⚠ Warning:**
Do not use the air conditioner if the insulation resistance is less than 1 MΩ.

Insulation resistance

After installation or after the power source to the unit has been cut for an extended period, the insulation resistance will drop below 1 MΩ due to refrigerant accumulating in the compressor. This is not a malfunction. Perform the following procedures.

1. Remove the wires from the compressor and measure the insulation resistance of the compressor.
2. If the insulation resistance is below 1 MΩ, the compressor is faulty or the resistance dropped due to the accumulation of refrigerant in the compressor.

3. After connecting the wires to the compressor, the compressor will start to warm up after power is supplied. After supplying power for the times indicated below, measure the insulation resistance again.
 - The insulation resistance drops due to accumulation of refrigerant in the compressor. The resistance will rise above 1 MΩ after the compressor is warmed up for 12 hours.
(The time necessary to warm up the compressor varies according to atmospheric conditions and refrigerant accumulation.)
 - To operate the compressor with refrigerant accumulated in the compressor, the compressor must be warmed up at least 12 hours to prevent breakdown.
4. If the insulation resistance rises above 1 MΩ, the compressor is not faulty.

⚠ Caution:

- **The compressor will not operate unless the power supply phase connection is correct.**

- **Turn on the power at least 12 hours before starting operation.**

- Starting operation immediately after turning on the main power switch can result in severe damage to internal parts. Keep the power switch turned on during the operational season.

- ▶ **The followings must be checked as well.**

- The outdoor unit is not faulty. LED on the control board of the outdoor unit flash when the outdoor unit is faulty.
- Both the gas and liquid stop valves are completely open.

7.2. Test run

7.2.1. Using remote controller

Refer to the indoor unit installation manual.

- Be sure to perform the test run for each indoor unit. Make sure each indoor unit operates properly following the installation manual attached to the unit.
- If you perform the test run for all indoor units at once, you cannot detect any erroneous connection, if any, of the refrigerant pipes and the connecting wires.
 - * The compressor operation is not available for 3 minutes at least after the power is supplied.
 - * The compressor can emit noise just after turn on the power supply or in case of low outside air temperature.

About the restart protective mechanism

Once the compressor stops, the restart preventive device operates so the compressor will not operate for 3 minutes to protect the air conditioner.

7.2.2. Using SW3 in outdoor unit

Note:

In case of the test run from outdoor unit, all indoor units operate. Therefore, you can not detect any erroneous connection of refrigerant pipes and the connecting wires. If it aims at detection of any erroneous connection, be sure to carry out the test run from remote controller with reference to "7.2.1. Using remote controller".

■ Test run (from the outdoor unit)

- ① Set SW3-2 to select the operation mode.

SW3-2	ON	Heating operation
	OFF	Cooling operation

- ② After setting SW3-2, set SW3-1 from OFF to ON. The test run starts.
 - * Before setting SW3-1, make sure that the circuit breaker is turned on.
 - * Even if the setting for SW3-2 changes during the test run, the operation mode will not change.
 - * Set SW3-1 to OFF to finish the test run.
- A few seconds after the compressor starts, a clanging noise may be heard from the inside of the outdoor unit. The noise is coming from the check valve due to the small difference in pressure in the pipes. The unit is not faulty.

7.3. Refrigerant collecting (Pump down)

Perform the following procedures to collect the refrigerant when moving the indoor unit or the outdoor unit.

- ① Turn off the circuit breaker.
- ② Connect the low pressure side of the gauge manifold to the service port of the gas side stop valve.
- ③ Close the liquid stop valve.
- ④ Supply power (circuit breaker).
 - * Start-up of the indoor-outdoor communication takes about 3 minutes after the power (circuit breaker) is turned on. Start the pump-down operation 3 to 4 minutes after the power (circuit breaker) is turned ON.
- ⑤ Confirm that SW3-2 is set to OFF, and then set SW3-1 to ON to perform the test run for cooling operation. The compressor (outdoor unit) and ventilators (indoor and outdoor units) start operating and test run for cooling operation begins. Immediately after performing the test run for cooling operation, set the outdoor service switch SW2-4 (pump down switch) from OFF to ON.
 - * Do not continue to operate for a long time with the switch SW2-4 set to ON. Make sure to switch it to OFF after pump down is completed.

- ⑥ Fully close the gas stop valve when the pressure reading on the gauge drops 0.05 - 0.00 MPa (approximately 0.5 - 0.0 kgf/cm²)
- ⑦ Stop the air conditioner operation (SW3-1: OFF). Set the outdoor service switch SW2-4 from ON to OFF.
- ⑧ Turn off the power supply (circuit breaker).
 - * If too much refrigerant has been added to the air conditioner system, the pressure may not drop to 0.05 MPa (0.5 kgf/cm²). If this occurs, use a refrigerant collecting device to collect all of the refrigerant in the system, and then recharge the system with the correct amount of refrigerant after the indoor and outdoor units have been relocated.

⚠ Warning:

When pumping down the refrigerant, stop the compressor before disconnecting the refrigerant pipes. The compressor may burst and cause injury if any foreign substance, such as air, enters the system.

8. Special functions

8.1. OUTDOOR UNIT INPUT/OUTPUT CONNECTOR

• State (CN51)

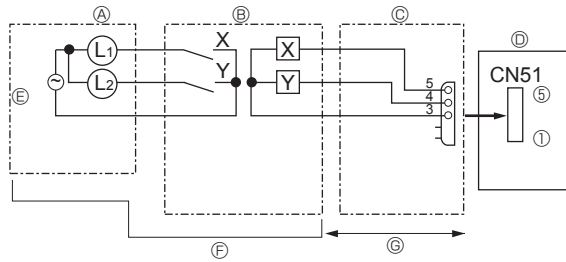

- Ⓐ Distant control board
- Ⓑ Relay circuit
- Ⓒ External output adapter (PAC-SA88HA-E)
- Ⓓ Outdoor unit control board

- Ⓔ Lamp power supply
- Ⓕ Procure locally
- Ⓖ Max. 10 m

L1: Error display lamp
 L2: Compressor operation lamp
 X, Y: Relay (coil rating: ≤ 0.9 W, 12 VDC)

• Demand Response Mode (CN3S, CN3D)

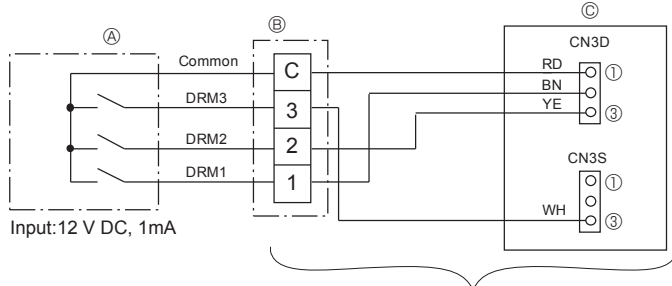

- Ⓐ DRED (Demand controller)
- Ⓑ Terminal block
- Ⓒ Outdoor unit control board

The wiring between Ⓑ and Ⓒ is completed before shipping from the factory.

This product is capable of all three Demand Response Mode (DRM1, 2, 3). (DRED compliant to AS/NZS 4755.3.1:2012)

Demand Response Mode	Description
DRM1	Compressor Off.
DRM2	Total electrical energy consumption of the system is not more than 50%.
DRM3	Total electrical energy consumption of the system is not more than 75%.

• Silent Mode / Demand Control (CN3D)

To use this function, DIP switch SW5-1 must be set to OFF and the existing CN3S and CN3D lead wires must be removed. In addition, this function cannot be used at the same time as the Demand Response Modes above.

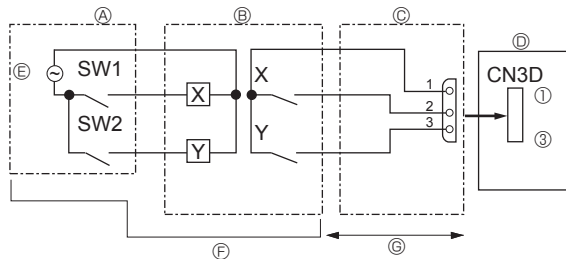

- Ⓐ Remote control panel
- Ⓑ Relay circuit
- Ⓒ External input adapter (PAC-SC36NA-E)
- Ⓓ Outdoor unit control board

- Ⓔ Relay power supply
- Ⓕ Procure locally
- Ⓖ Max. 10 m

SW1: Switch
 SW2: Switch
 X, Y: Relay (contact rating: ≥ 0.1 A, 15 VDC)
 (min. applicable load: ≤ 1 mA)

The silent mode and the demand control are selected by switching the DIP switch 9-2 on outdoor controller board. It is possible to set it to the following power consumption (compared with ratings) by setting SW1, 2.

	Outdoor controller board DIP SW9-2	SW1	SW2	Function
Silent mode (Cooling only)	OFF	OFF	OFF	Normal
		ON	OFF	Silent mode
		OFF	ON	Super silent mode 1
		ON	ON	Super silent mode 2
Demand control	ON	OFF	OFF	100% (Normal)
		ON	OFF	75%
		ON	ON	50%
		OFF	ON	0% (Stop)

• External static pressure mode (30 Pa)

The external static pressure mode (30 Pa) is enabled by switching the DIP switch SW6-5 on the outdoor controller board to ON. However, the silent mode cannot be used when this mode is enabled.

Outdoor controller board DIP SW6-5	ON	OFF
External static pressure mode (30 Pa)	Enabled	Disabled

9. Installation and operation manual for demand response (DRED)

This unit has demand response capability which is compliant with AS/NZS 4755.3.1: 2012.

To activate this function, you need to make a contract with remote agents such as electric supply company, then this unit should be connected to Demand response enabling device (DRED). For further information, consult your dealer. This unit supports 3 Demand Response Modes (DRMs): DRM1, DRM2 and DRM3.

WARNING

- | | |
|--|--|
| <ul style="list-style-type: none"> ■ Ask your dealer or technical representative to install the unit.
Any deficiency caused by your own installation may result in an electric shock or fire. ■ Ensure that installation work is done correctly following this instruction manual.
Any deficiency caused by installation may result in an electric shock or fire. ■ Firmly connect the wiring using the specified cables. Carefully check that the cables do not exert any forces on the terminals.
Improper wiring connections may produce heat and possibly a fire. ■ Never try any modification.
Any deficiency caused by your modification or repair may result in an electric shock or fire. Consult with your dealer about repair. | <ul style="list-style-type: none"> ■ All electrical work must be performed by a licensed technician, according to local regulations and the instructions given in this manual.
Any lack of electric circuit or any deficiency caused by installation may result in an electric shock or fire. ■ Do not move and re-install this device yourself.
Any deficiency caused by installation may result in an electric shock or fire. Ask your distributor or special vendor for moving and installation. ■ Stop the operation if any malfunction occurs.
If malfunction occurs (burning smell, etc.) stop the operation and turn off the power supply. Contact your dealer or technical representative. If the controller continues to operate after a malfunction occurs, this may cause damage, electric shock or fire. ■ Do not turn on the main power until installation has been completed.
Doing so may result in electric shock or fire. |
|--|--|

CAUTION

- | | |
|---|--|
| <ul style="list-style-type: none"> ■ Wire so that it does not receive any tension.
Tension may cause wire breakage, heating or fire. ■ Use standard wires in compliance with the current capacity.
A failure to this may result in an electric leakage, heating or fire. ■ Do not wash with water.
Doing so may cause an electric shock or malfunction. | <ul style="list-style-type: none"> ■ Do not connect the demand control transmission cable to the terminal block for power supply. ■ Do not pull, extremely bend or apply strong pressure on the wire to prevent failure. ■ Do not screw DRED to outdoor unit. ■ Do not put DRED in outdoor unit. ■ Secure electrical wiring above clamp. ■ Do not get DRED wire caught in the panel. ■ Secure the power supply cord, indoor/outdoor unit connecting wire and DRED wire with the clamp and band.
The band is not used for the PUMY-SP-VKMD. |
|---|--|

Remote Controller display

(PAR-33MAA)

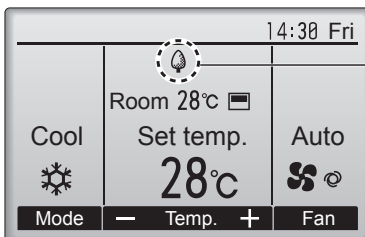

 will appear on the Main display while the product is operating in a demand response mode.

9. Installation and operation manual for demand response (DRED)

9.1. Parts List

- ACCESSORIES
(Check the following parts before installation.)

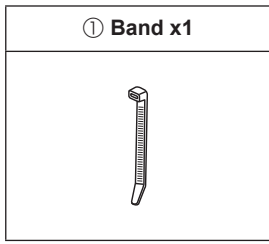

- PARTS TO BE PROVIDED AT YOUR SITE

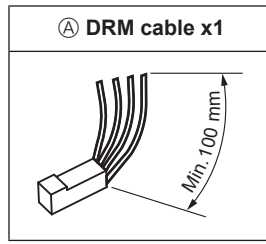

9.2. Installation procedure

■ PUMY-SP•VKMD

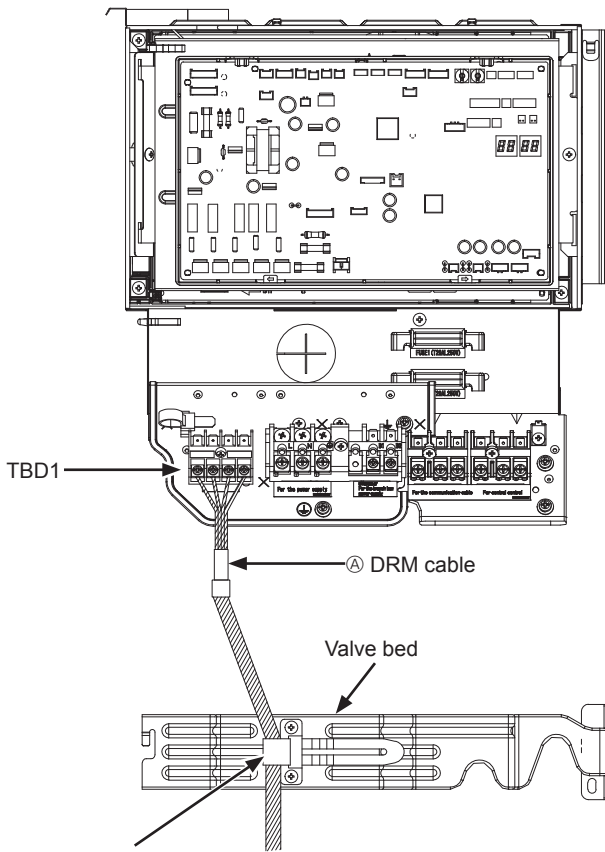

- Fix by clamp
- The band is not used for the PUMY-SP•VKMD.

■ PUMY-SP•YKMD

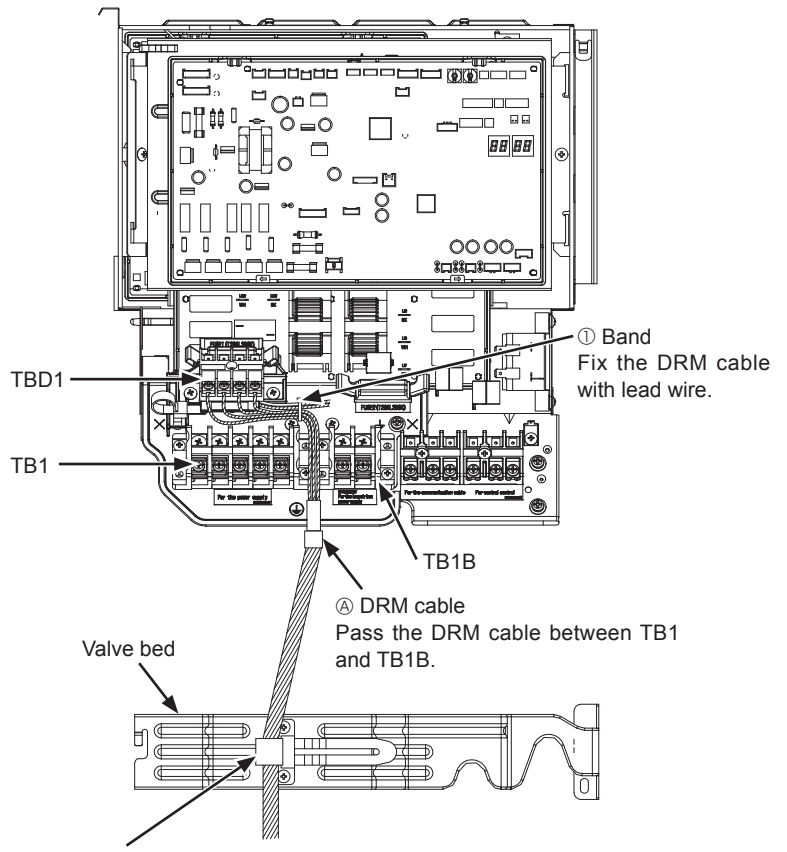

9.3. When connecting the DRED.

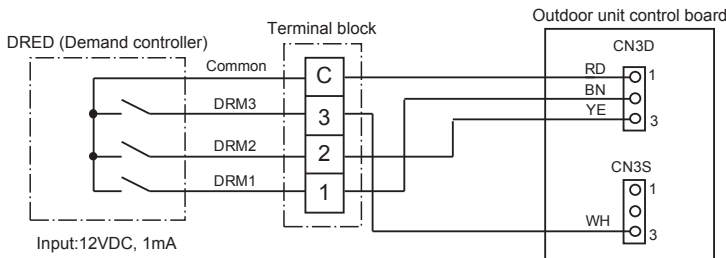

DipSW setting

SW5-1	SW9-2	Function
OFF	OFF	Silent Mode
ON	ON	Existing Demand Mode
ON	OFF	Silent Mode
ON	ON	Demand Response Mode (DRM)

- The unit is set to default settings as in the shaded area (Demand Response Mode (DRM) (SW5-1:ON, SW9-2:ON)) when shipped.
- Refer to the service manual for details about the functions of the unit other than Demand Response Mode (DRM).

Model	Wire specifications
Outdoor unit	Demand control signal transmission cable *1 0.5 - 1.5 mm ²

*1 Use wires in conformity with design AS/NZS 5000.2.

9. Installation and operation manual for demand response (DRED)

9.4. Demand response mode

This unit has demand response capability which is compliant with AS/NZS 4755.3.1: 2012.

To activate this function, you need to make a contract with remote agents such as electric supply company, then this unit should be connected to Demand response enabling device (DRED). For further information, consult your dealer.

Demand response represents the automated alteration of an electrical product's normal mode of operation in response to an initiating signal originating from or defined by a remote agent.

This unit supports 3 Demand Response Modes (DRMs).

DRM	Description of operation in this mode
DRM 1	Compressor off The air conditioner does not perform cooling or heating operation during the demand response event.
DRM 2	The air conditioner continues to perform cooling or heating operation during the demand response event, but the electrical energy consumed by the air conditioner in a half hour period is not more than 50% of the total electrical energy that would be consumed if operating at the rated capacity in a half hour period.
DRM 3	The air conditioner continues to perform cooling or heating operation during the demand response event, but the electrical energy consumed by the air conditioner in a half hour period is not more than 75% of the total electrical energy that would be consumed if operating at the rated capacity in a half hour period.

Note:

- DRM is automatically activated or released according to the signals from DRED.
DRM cannot be invalidated or changed manually.
- You might feel this unit does not sufficiently perform cooling or heating operation during DRM.
- Operation settings can be changed as usual with the remote controller during DRM.
However, you might not feel cool or warm enough as DRM is prioritized.
- When this unit receives the DRM1 signal, the response time until the DRM1 mode is activated is within 60 sec.
However, if the maintenance and safety modes are activated, those modes have priority.
- The terminal block for the DRED satisfies the ELV requirements.

This product is designed and intended for use in the residential,
commercial and light-industrial environment.

Please be sure to put the contact address/telephone number on
this manual before handing it to the customer.

MITSUBISHI ELECTRIC CORPORATION

HEAD OFFICE: TOKYO BUILDING, 2-7-3, MARUNOUCHI, CHIYODA-KU, TOKYO 100-8310, JAPAN