

# *RS232/LAN Serial Communication Control*

## *Specification for A2129 (MDT552S/LDT552V)*

---

### 1. Application

This document defines the communication protocols for serial control of the A2129(MDT552S/LDT552V).

A2129: A common regulatory name for MDT552S and LDT552V. This model name is noted on rating label.

MDT552S: A model name for the market, US, EU and Asia and others, except for Japan.

LDT552V: A model name for the Japan market.

#### -----Revision History-----

1<sup>st</sup> release                      Dec. 15<sup>th</sup> 2012                      H.Tanizoe, M.Hayashi, M.Juichiya, Y.Ashizaki

### Index

1.	Application .....	1
2.	Connectors and wiring .....	2
3.	Communication Parameter .....	3
4.	Communication Format .....	6
5.	Message type .....	14
6.	Typical procedure example .....	19
7.	Power control procedure .....	24
8.	Asset Data read and write .....	26
9.	Date & Time read and write .....	28
10.	Schedule read and write .....	32
11.	Self diagnosis .....	37
12.	Serial No. & Model Name Read .....	39
13.	Control Commands for Auto Brightness function .....	41
14.	Control Commands for Automatic ID Assignment function .....	49

### Appendix

A.	Operation Code (OP code) Table .....	51
B.	Application Note for LAN based communication .....	56
C.	Power control timing instruction for OPS PC .....	57

## 2. Connectors and wiring

You connect the computer and the displays with serial cables for the display control.  
You can use one of serial communication control ports with selecting whether RS-232C or LAN.

### A: RS-232C connection

Connector: D-Sub 9-pin

Cable: Cross (reversed) cable or null modem cable

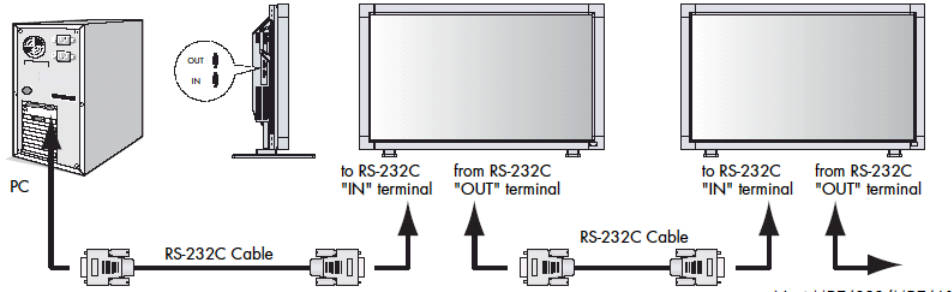

### B: LAN connection

Connector: Modular 8pin (RJ45)

Cable: Modular 8pin (RJ45), Strait CAT5/6/7 LAN cable

\* If you connect one PC and one display without LAN HUB, you use Cross LAN cable.

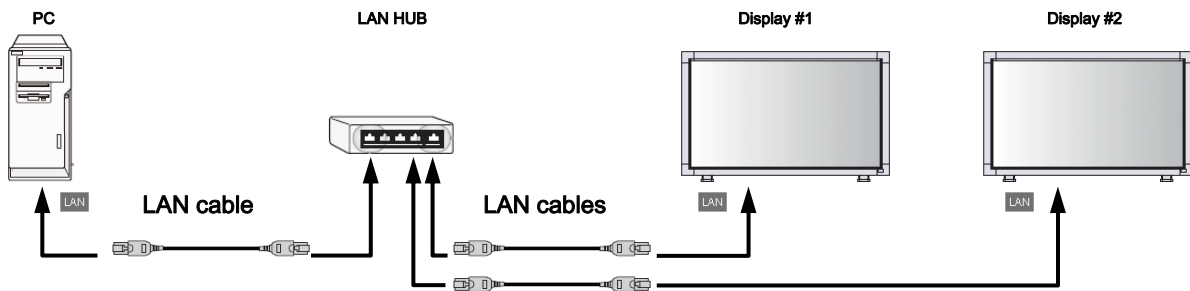

**Note:** LAN control is converted to RS-232C control in the display.

### 3. Communication Parameter

Set each communication parameters to the PC connected with each kind of cable.

#### A: RS-232C connection

(1) RS-232C direct connection between PC and Display

Interface	RS-232C (Asynchronous, Full-duplex)
Baud rate	9600bps
Data length	8bits
Parity	None
Stop bit	1 bit
Flow control	None
Communication code	ASCII
Communication signals	TXD, RXD

#### B: LAN connection

(1) LAN connection between PC and Display

Interface	TCP/IP
DHCP client mode	Changeable (default = OFF: not using)
IP address	Changeable (default = 192.168.0.10: depends on model)
Subnet mask	Changeable (default = 255.255.255.0)
Default gateway	Changeable (default = 192.168.0.1: depends on model)
Port	3007/63007 (Both of those ports are available. Use 63007 only if you have no support of legacy products.)

### 3.1 Communication timing

The controller should wait for a packet interval before next command is sent.

The packet interval needs to be longer than 600msec for the A2129(MDT552S/LDT552V)".

#### [Important Information]

HOST system shall send next command after receiving a reply command from Monitor, if it is sequential commands communication. If Host doesn't wait for monitor's reply, monitor operation error may happen.

Time-out error handling operation in Controller: Host Controller shall wait the reply from Monitor, after sending command as mentioned above. The time-out setting in Host Controller shall be more than 30sec after sending command to Monitor. (Using the maximum command interval "a<sub>MAX</sub>" is most safety.)

Communication disabled period after power on/off: After Monitor Power on, either by AC switch, Remote Controller or Serial communication command, Monitor goes initialize mode of controller and can not handle the remote control commands correctly during the mode. So do NOT send any command at least 14sec after monitor power on/off. If you make the code which sends any command after POWER ON/OFF command, please put a wait at least 14sec after sending the command.

About the other commands, please wait the each periods of command interval from PC. (See below example.)

When your system may output no signal, you have to set the menu "POWER SAVE (PC)" to OFF because of 14sec waiting.

#### [Available Command list at DC power off status]

A2129(MDT552S/LDT552V) can't accept and reply any command except for the following commands when it is in DC power off or power saving.

Power status Read / Read Model name Read / Serial number Read / Power on / Power off

#### [Network latency with control via LAN]

If you control A2129(MDT552S/LDT552V) via LAN interface, the network latency time will affect the control timing of serial commands.

It is out of scope of document.

Please add necessary margin of wait time and interval of each command packet, based on the maximum available latency time with your system and add appropriate error handling operation into your control program.

## Example of communication timing

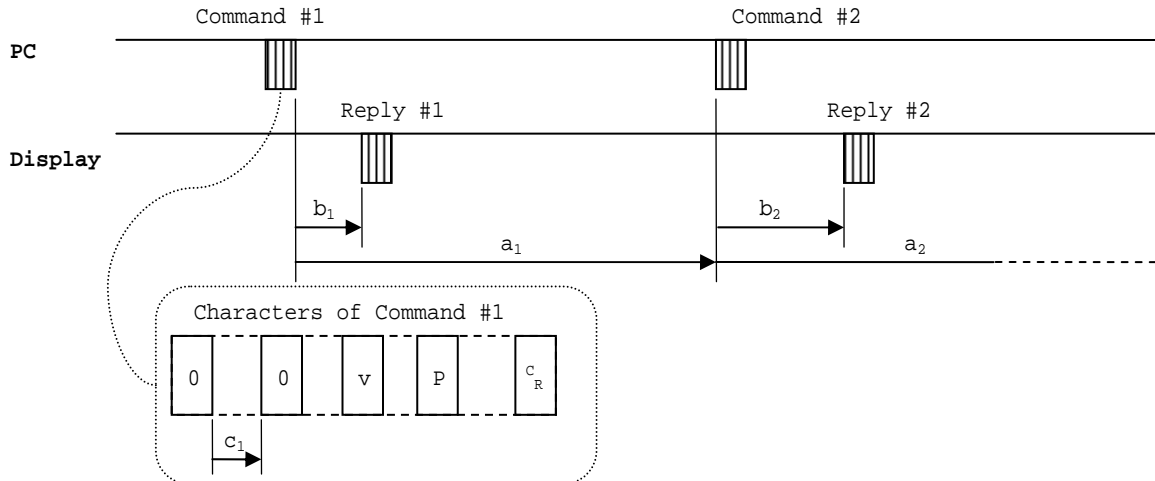

- \* Command interval from PC (Wait sending next command for processing in display.)
  - a > 14sec: When Command #1 is power command "POWER ON", "POWER OFF".
  - a > 5sec: When Command #1 is video input command "INPUT D-SUB", "INPUT VIDEO", etc.
  - a > 1.8sec: When Command #1 is store the adjusted value command "SAVE CURRENT SETTINGS", "SAVE CURRENT SETTINGS QUICK".
  - a > 6sec: When Command #1 is "AUTO SETUP".
  - a > 30sec: When Command #1 is "FACTORY RESET", "SCREEN RESET". (This results in  $a_{MAX}$ )
  - a > 15sec: When Command #1 is "Force powered off".
  - a > 600msec: When Command #1 is the others.
  
- \* Minimum reply time from display (Additional time depends on command processing in display)
  - b = 10msec (Typ.): On RS-232C connection (The time depends on models as 10 to 20msec.)
  - b = 30sec (max): When Command #1 is "FACTORY RESET", "SCREEN RESET".
  - b = 3sec (max): When Command #1 is video input command "INPUT D-SUB", "INPUT VIDEO", etc.
  - b < 200msec (max): When Command #1 is the others.
  
- \* Command internal gap (Don't make a longer interval gap between characters.)
 

[Following 3 steps of time out period is selectable by OSD menu "CONTROL TIMEOUT" in CONFIGURATION2 menu on POWER ON mode. Although c is 5sec on POWER OFF mode and sleep mode. ]

  - c < 10msec: Normal communication mode for time-out error of each character gap.
  - c < 2sec: Hand typing mode on teletype application.
  - c < 30sec: Hand typing mode with longer time-out.

(Infinity waiting isn't supported because of processing freeze.)

## 4. Communication Format

### 4.1. Basic command

This command set supports only the basic control of monitor and does NOT support multi monitor control by daisy chained connection. This command set will be written in the user's manual of A2129(MDT552S/LDT552V).

#### 1) Control command diagram

The command is structured by the address code, function code, data code and end code. The length of the command is different for each function.

	Address code	Function code	Data code	End code
HEX	30h 30h	Function	Data	0Dh
ASCII	'0' '0'	Function	Data	↵

[Address code] 30h 30h (In ASCII code, '0' '0') fixed.

[Function code] A code of each fixed control move.

[Data code] A code of each fixed control data (number) and not always indicated.

[End code] 0Dh (In ASCII code, '↵') fixed.

#### 2) Control sequence

(1) The command from a computer to the LCD monitor will be sent in 600ms.

(2) The LCD monitor will send a return command 600ms\* after it has received and encoded. If the command isn't received correctly, the LCD monitor will not send the return command.

(3) The personal computer checks the command and confirms if the command, which has been sent, has been executed or not.

(4) This LCD monitor sends various codes other than return code. When having a control sequence by RS-232C, reject other codes from personal computers side.

\*: The sending time of return command may delay depending on the condition (during changing of the input signal, etc.).

Example: Turn the power ON (' ' is for ASCII code)

Sending commands from the PC	Status code from LCD monitor	Meaning
30 30 21 0D '0' '0' '!' '↵'		Command for POWER ON
	30 30 21 0D '0' '0' '!' '↵'	Command received (Command echoed back)

Note: The replied status is for communication confirmation. When you want to know the display condition, please use the 'Read command'. (See page 7)

### 3) Operation commands

The operation commands execute the basic operation setting of this LCD monitor.

It may not operate when changing the signal:

Operation	ASCII	HEX
POWER ON	!	21h
POWER OFF	"	22h
FORCE POWER OFF WITH OPS	""	22h 22h
INPUT HDMI1	_r1	5Fh 72h 31h
INPUT HDMI2	_r7	5Fh 72h 37h
INPUT DVI-D	_r2	5Fh 72h 32h
INPUT D-SUB	_r3	5Fh 72h 33h
INPUT OPTION(OPS)	_r5	5Fh 72h 35h
INPUT DisplayPort	_r6	5Fh 72h 36h
INPUT VIDEO	_v1	5Fh 76h 31h
INPUT YPbPr(DVD/HD)	_v2	5Fh 76h 32h
INPUT S-VIDEO*	_v3	5Fh 76h 33h

\* S-VIDEO is SEPARATE only

### 4) Read command

Host computer sends the command without Data-code to monitor.

After receiving this command, the monitor returns the command with Data-code of current status to host computer.

< ex. > When Host computer ask Power status of monitor, the status of monitor is powered-on.

Command from computer	Command from Monitor	Detail of command
30 30 76 50 0D 0"0"v"P"[enter]		Ask about the power status of monitor.
	30 30 76 50 31 0D 0"0"v"P"1"[enter]	Monitor is powered-on.

Structure of the Read-command

		ASCII		HEX	
		Function	Data (Receive)	Function	Data (Receive)
POWER	ON	vP	1	76 50	31
	OFF(sleep/stand by)	vP	0	76 50	30
Input	HDMI1	vl	r1	76 49	72 31
	HDMI2	vl	r7	76 49	72 37
	DVI-D	vl	r2	76 49	72 32
	D-SUB	vl	r3	76 49	72 33
	OPTION	vl	r5	76 49	72 35
	DisplayPort	vl	r6	76 49	72 36
	Video	vl	v1	76 49	76 31
	YPbPr(DVD/HD)	vl	v2	76 49	76 32
	S-VIDEO	vl	v3	76 49	76 33
Picture mode	HIGHBRIGHT	vM	p1	76 4D	70 31
	STANDARD	vM	p2	76 4D	70 32
Temperature of Internal monitor	Around Main board resolution 1°C	tc1	(ex.) +25	74 63 31	2B 20 32 35
	Around Power PCB resolution 1°C	tc2	(ex.) +31	74 63 32	2B 20 33 31

5) Remote command

(Not executable in sleep/standby mode. When the remote commands are sent while sleep/standby mode, the sleep/stand-by mode is only canceled.)

Some remote control operations can be achieved by the remote command codes. The remote commands have no data codes.

Button's name on remote	Function	
	Character	ASCII
+/VOLUME	r06	72h 30h 36h
-/VOLUME	r07	72h 30h 37h
AV MUTE	ra6	72h 61h 36h
AUTO SETUP	r09	72h 30h 39h

[Example] When executing the AUTO SETUP. (Figures and symbols enclosed in quotation marks are ASCII codes.):

Sending commands from the PC, etc.	Status code from the projector	Description
'30' '30' '72' '30' '39' '0D' 00r09 [ ]		Command operating the same as the MENU button
	'30' '30' '72' '30' '39' '0D' 00r09 [ ]	Command receipt confirmation (Command echo back)

Note:

When you use a terminal application with typing the codes by hands, DO NOT type BS (Back Space) key or the other control keys. The behavior may send unexpected codes in Sending command to the monitor. The communication may be rejected by the monitor, or the monitor may result in unexpected operation in the worst case.



## 4.2. Extended command

**Note: This command set supports multi monitor control by daisy chained connection. This command set will NOT be written in the user's manual of A2129(MDT552S/LDT552V).**

The command packet consists of four parts, Header, Message, Check code and Delimiter.

Header	Message	Check Code	Delimiter
--------	---------	------------	-----------

Sequence of a typical procedure to control a monitor is as follows,

[A controller and a monitor, two-way communication composition figure]

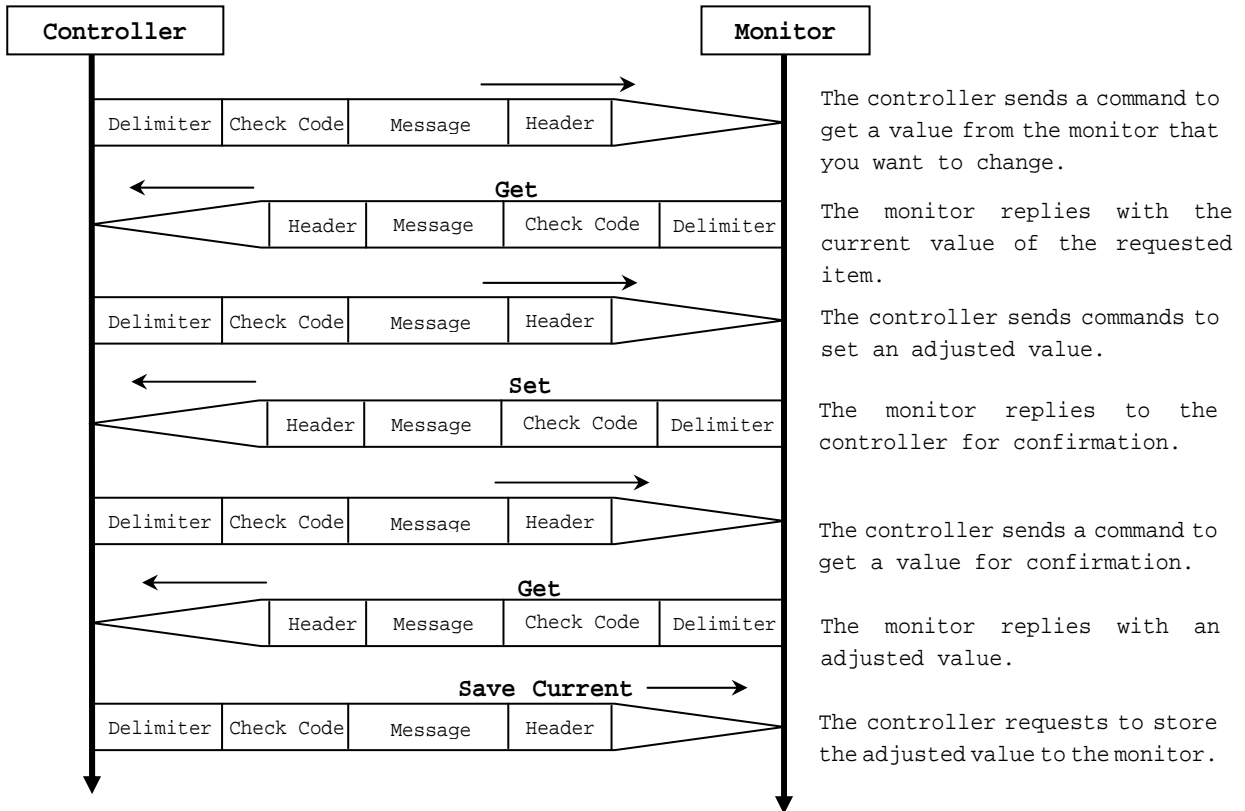

### 4.3 Header block format (fixed length)

Header	Message	Check code	Delimiter
--------	---------	------------	-----------

SOH	Reserved '0'	Destination 'A'	Source	Message Type	Message Length
1 <sup>st</sup>	2 <sup>nd</sup>	3 <sup>rd</sup>	4 <sup>th</sup>	5 <sup>th</sup>	6 <sup>th</sup> -7 <sup>th</sup>

1<sup>st</sup> byte) SOH: Start of Header  
ASCII SOH (01h)

2<sup>nd</sup> byte) Reserved: Reserved for future extensions.  
A2129(MDT552S/LDT552V) must be ASCII '0'(30h)

3<sup>rd</sup> byte) Destination: Destination equipment ID. (Receiver)  
Specify a command's receiver's address.

If the command should be sent to certain monitor only, the either of character 'A'(41h) to 'Z'(5Ah) which is corresponding to monitor ID from No1 to No.26 should be set to this portion. If it is a broad cast command (only "set command" is available), then the '\*'(2Ah) should be applied.

4<sup>th</sup> byte) Source: Source equipment ID. (Sender)  
Specify a sender address.  
The controller must be '0'(30h).

5<sup>th</sup> byte) Message Type: (Case sensitive.)  
Refer to section 4.2 "Message block format" for more details.

- ASCII 'A' (41h): Command
- ASCII 'B' (42h): Command reply.
- ASCII 'C' (43h): Get current parameter from a monitor.
- ASCII 'D' (44h): "Get parameter" reply.
- ASCII 'E' (45h): Set parameter.
- ASCII 'F' (46h): "Set parameter" reply.

6<sup>th</sup> -7<sup>th</sup> bytes) Message Length:  
Specify the length of the message (that follows the header) from STX to ETX.  
This length includes STX and ETX.  
The byte data must be encoded to ASCII characters.  
Ex.) The byte data 3Ah must be encoded to ASCII characters '3' and 'A' (33h and 41h).  
The byte data 0Bh must be encoded to ASCII characters '0' and 'B' (30h and 42h).

Header	Message	Check code	Delimiter
--------	---------	------------	-----------

## 4.4 Message block format

"Message block format" is allied to the "Message Type" in the "Header".

Refer to the section 6 "Message format" for more detail.

### 1) Get current parameter

The controller sends this message when you want to get the status of the monitor.

For the status that you want to get, specify the "OP code page" and "OP code", refer to "Appendix A. Operation code table".

"Message format" of the "Get current parameter" is as follows;

STX	OP code page		OP code		ETX
	Hi	Lo	Hi	Lo	

Refer to section 5.1 "Get current parameter from a monitor." for more details.

### 2) Get Parameter reply

The monitor will reply with the status of the requested item specified by the controller in the "Get parameter message".

"Message format" of the "Get parameter reply" is as follows;

STX	Result		OP code page		OP code		Type		Max value			Current Value			ETX
	Hi	Lo	Hi	Lo	Hi	Lo	Hi	Lo	MSB			LSB	MSB		

Refer to section 5.2 "Get parameter reply" for more details.

### 3) Set parameter

The controller sends this message to change a setting of the monitor.

Message format of the "Set parameter" is as follows;

STX	OP code page		OP code		Set Value				ETX
	Hi	Lo	Hi	Lo	MSB			LSB	

Refer to section 5.3 "Set parameter" for more details.

### 4) Set Parameter reply

The monitor replies with this message for a confirmation of the "Set parameter message".

Message format of the "Set parameter reply" is as follows;

STX	Result		OP code page		OP code		Type		Max value			Requested setting Value			ETX
	Hi	Lo	Hi	Lo	Hi	Lo	Hi	Lo	MSB			LSB	MSB		

Refer to section 5.4 "Set parameter reply" for more details.

### 5) Command

"Command message" format depends on each command.

Usually, this "command message" is used for some non-slider controls and some special operations, such as "Save current settings", "Get timing report", "power control", "Schedule", etc. Refer to section 5.5 "Commands message" for more details.

6) Command reply

The monitor replies to a query from the controller.

"Command reply message" format depends on each command.

Refer to section 5.5 "Commands message" for more details.

#### 4.5 Check code

Header	Message	<b>Check code</b>	Delimiter
--------	---------	-------------------	-----------

Check code is the Block Check Code (BCC) between the Header and the End of Message except SOH.

		$2^7$	$2^6$	$2^5$	$2^4$	$2^3$	$2^2$	$2^1$	$2^0$
SOH	D <sub>0</sub>								
Reserved	D <sub>1</sub>								
Destination	D <sub>2</sub>								
Source	D <sub>3</sub>								
Type	D <sub>4</sub>								
Length	D <sub>5</sub>								
STX	D <sub>6</sub>								
Data	D <sub>7</sub>								
ETX	D <sub>n</sub>								
Check code	D <sub>n+1</sub>	P	P	P	P	P	P	P	P

$$D_{n+1} = D_1 \text{ XOR } D_2 \text{ XOR } D_3 \text{ XOR } \dots \text{ XOR } D_n$$

XOR: Exclusive OR

Following is an example of a Check code (BCC) calculation.

Header							Message										Check code (BCC)	Delimiter
SOH	Reserved	Destination Address	Source Address	Message type	Message length		STX	OP code page		OP code		Set Value				ETX		
01	30	41	30	45	30	41	02	30	30	31	30	30	30	36	34	03	77	0D
D <sub>0</sub>	D <sub>1</sub>	D <sub>2</sub>	D <sub>3</sub>	D <sub>4</sub>	D <sub>5</sub>	D <sub>6</sub>	D <sub>7</sub>	D <sub>8</sub>	D <sub>9</sub>	D <sub>10</sub>	D <sub>11</sub>	D <sub>12</sub>	D <sub>13</sub>	D <sub>14</sub>	D <sub>15</sub>	D <sub>16</sub>	D <sub>17</sub>	D <sub>18</sub>

$$\begin{aligned}
 \text{Check code (BCC) } D_{17} &= D_1 \text{ xor } D_2 \text{ xor } D_3 \text{ xor } \dots \text{ xor } D_{14} \text{ xor } D_{15} \text{ xor } D_{16} \\
 &= 30\text{h xor } 41\text{h xor } 30\text{h xor } 45\text{h xor } 30\text{h xor } 41\text{h} \\
 &\quad \text{xor } 02\text{h xor } 30\text{h xor } 30\text{h xor } 31\text{h xor } 30\text{h xor } 30\text{h} \\
 &\quad \text{xor } 30\text{h xor } 36\text{h xor } 34\text{h xor } 03\text{h} \\
 &= 77\text{h}
 \end{aligned}$$

#### 4.6 Delimiter

Header	Message	Check code	<b>Delimiter</b>
--------	---------	------------	------------------

Packet delimiter code; ASCII CR(0Dh).

## 5. Message type

### 5.1 Get current Parameter from a monitor.

STX	OP code page		OP code		ETX
	Hi	Lo	Hi	Lo	
1 <sup>st</sup>	2 <sup>nd</sup> -3 <sup>rd</sup>		4 <sup>th</sup> -5 <sup>th</sup>		6 <sup>th</sup>

Send this message when you want to get the status of a monitor.

For the status that you want to get, specify the "OP code page" the "OP code", refer to "Appendix A. Operation code table".

1<sup>st</sup>byte) STX: Start of Message

ASCII STX (02h)

2<sup>nd</sup>-3<sup>rd</sup>bytes) OP code page: Operation code page.

Specify the "OP code page" for the control which you want to get the status.

Refer to "Appendix A Operation code table" for each item.

OP code page data must be encoded to ASCII characters.

Ex.) The byte data 02h must be encoded to ASCII characters '0' and '2' (30h and 32h).

OP code page 02h -> OP code page (Hi) = ASCII '0' (30h)

OP code page (Lo) = ASCII '2' (32h)

Refer to Operation code table. (Appendix A)

4<sup>th</sup>-5<sup>th</sup>bytes) OP code: Operation code

Refer to "Appendix A Operation code table" for each item.

OP code data must be encoded to ASCII characters.

Ex.) The byte data 3Ah must be encoded to ASCII characters '3' and 'A' (33h and 41h).

OP code 3Ah -> OP code (Hi) = ASCII '3' (33h)

OP code (Lo) = ASCII 'A' (41h)

Refer to Operation code table.

6<sup>th</sup>byte) ETX: End of Message

ASCII ETX (03h)

### 5.2 "Get parameter" reply

STX	Result		OP code page		OP code		Type		Max value			Current Value				ETX
	Hi	Lo	Hi	Lo	Hi	Lo	Hi	Lo	MSB		LSB	MSB		LSB		
1 <sup>st</sup>	2 <sup>nd</sup> -3 <sup>rd</sup>		4 <sup>th</sup> -5 <sup>th</sup>		6 <sup>th</sup> -7 <sup>th</sup>		8 <sup>th</sup> -9 <sup>th</sup>		10 <sup>th</sup> -13 <sup>th</sup>			14 <sup>th</sup> -17 <sup>th</sup>				18 <sup>th</sup>

A2129(MDT552S/LDT552V) replies with a current value and the status of the requested item (operation code).

1<sup>st</sup>byte) STX: Start of Message

ASCII STX (02h)

2<sup>nd</sup>-3<sup>rd</sup>bytes) Result code.

These bytes indicate a result of the requested commands as follows,

00h: No Error.

01h: Unsupported operation with this monitor or unsupported operation under current condition.

This result code from the monitor is encoded to ASCII characters.

Ex.) The byte data 01h is encoded to ASCII character '0' and '1' (30h and 31h).

4<sup>th</sup>-5<sup>th</sup>bytes) OP code page: Operation code page.

These bytes indicate a replying item's OP code page.

This returned value from the monitor is encoded to ASCII characters.

Ex.) The byte data 02h is encoded to ASCII character '0' and '2' (30h and 32h).

Refer to the operation codes table.

6<sup>th</sup> -7<sup>th</sup>bytes) OP code: Operation code

These bytes indicate a replying item's OP code.

This returned value from the monitor is encoded to ASCII characters.

Refer to the operation code table.

Ex.) The byte data 1Ah is encoded to ASCII character '1' and 'A' (31h and 41h).

8<sup>th</sup> -9<sup>th</sup>bytes) Type: Operation type code

This returned value from the monitor is encoded to ASCII characters.

Ex.) The byte data 01h is encoded to ASCII character '0' and '1' (30h and 31h).

00h: Set parameter

01h: Momentary

Like the Auto Setup function which automatically changes the parameter.

10<sup>th</sup>-13<sup>th</sup>bytes) Max. value: Maximum value which monitor can accept. (16bits)

This returned value from the monitor is encoded to ASCII characters.

Ex.) '0', '1', '2' and '3' means 0123h (291)

14<sup>th</sup> -17<sup>th</sup>bytes) Current Value: (16bits)

This returned value from the monitor is encoded to ASCII characters.

Ex.) '0', '1', '2' and '3' means 0123h (291)

18<sup>th</sup>byte) ETX: End of Message

ASCII ETX (03h)

### 5.3 Set parameter

STX	OP code page		OP code		Set Value				ETX
	Hi	Lo	Hi	Lo	MSB		LSB		
1 <sup>st</sup>	2 <sup>nd</sup> -3 <sup>rd</sup>		4 <sup>th</sup> -5 <sup>th</sup>		6 <sup>th</sup> -9 <sup>th</sup>				10 <sup>th</sup>

Send this message to change monitor's adjustment and so on.

The controller requests a monitor to change value.

1<sup>st</sup>byte) STX: Start of Message

ASCII STX (02h)

2<sup>nd</sup>-3<sup>rd</sup>bytes) OP code page: Operation code page

This OP code page data must be encoded to ASCII characters.

Ex) The byte data 02h must be encoded to ASCII '0' and '2' (30h and 32h).

Refer to the Operation code table.

4<sup>th</sup>-5<sup>th</sup>bytes) OP code: Operation code

This OP code data must be encoded to ASCII characters.

OP code 1Ah -> OP code (Hi) = ASCII '1' (31h)

OP code (Lo) = ASCII 'A' (41h)

Refer to the Operation code table.

6<sup>th</sup>-9<sup>th</sup>bytes) Set value:(16bit)

This data must be encoded to ASCII characters.

Ex.) 0123h -> 1<sup>st</sup>(MSB) = ASCII '0' (30h)

2<sup>nd</sup> = ASCII '1' (31h)

3<sup>rd</sup> = ASCII '2' (32h)

4<sup>th</sup>(LSB) = ASCII '3' (33h)

10<sup>th</sup>byte) ETX: End of Message

ASCII ETX (03h)

#### 5.4 "Set parameter" reply

STX	Result		OP code page		OP code		Type		Max value			Requested setting Value			ETX
	Hi	Lo	Hi	Lo	Hi	Lo	Hi	Lo	MSB		LSB	MSB		LSB	
1 <sup>st</sup>	2 <sup>nd</sup> -3 <sup>rd</sup>		4 <sup>th</sup> -5 <sup>th</sup>		6 <sup>th</sup> -7 <sup>th</sup>		8 <sup>th</sup> -9 <sup>th</sup>		10 <sup>th</sup> -13 <sup>th</sup>			14 <sup>th</sup> -17 <sup>th</sup>			18 <sup>th</sup>

The Monitor echoes back the parameter and status of the requested operation code.

(If command is sent as "Broadcast" then no reply should be sent back.)

1<sup>st</sup>byte) STX: Start of Message

ASCII STX (02h)

2<sup>nd</sup>-3<sup>rd</sup>bytes) Result code

ASCII '0' '0' (30h, 30h): No Error

ASCII '0' '1' (30h, 31h): Unsupported operation with this monitor or unsupported operation under current condition.

4<sup>th</sup>-5<sup>th</sup>bytes) OP code page: Echoes back the Operation code page for confirmation.

Reply data from the monitor is encoded to ASCII characters.

Ex.) OP code page 02h -> OP code page = ASCII '0' and '2' (30h and 32h)

Refer to Operation code table.

6<sup>th</sup>-7<sup>th</sup>bytes) OP code: Echoes back the Operation code for confirmation.

Reply data from the monitor is encoded to ASCII characters.

Ex.) OP code 1Ah -> OP code (Hi) = ASCII '1' (31h)

OP code (Lo) = ASCII 'A' (41h)

Refer to Operation code table

8<sup>th</sup>-9<sup>th</sup>bytes) Type: Operation type code



ASCII '0'0' (30h, 30h): Set parameter

ASCII '0'1' (30h, 31h): Momentary

Like Auto Setup function, that automatically changes the parameter.

10<sup>th</sup>-13<sup>th</sup>bytes) Max. value: Maximum value that monitor can accept. (16bits)

Reply data from the monitor is encoded to ASCII characters.

Ex.) '0'1'2'3' means 0123h (291)

14<sup>th</sup> -17<sup>th</sup>bytes) Requested setting Value: Echoes back the parameter for confirmation. (16bits)

Reply data from the monitor is encoded to ASCII characters.

Ex.) '0'1'2'3' means 0123h (291)

18<sup>th</sup>byte) ETX: End of Message

ASCII ETX (03h)

## 5.5 Commands

"Command message format" depends on each command. Some commands are shown with usage. Refer to section 7 to 10.

### 5.5.1 Save Current Settings.

The controller requests for the monitor to store the adjusted value.

STX	Command code		ETX
	'0'	'C'	

- Send "0C"(30h, 43h) as Save current settings command.
- Complete "Save Current setting" command packet as follows;  
(The destination "A" (monitor ID of 1) is only an example. It should be changed according to the target monitor ID)

ASCII: 01h-30h-41h-30h-41h-30h-34h-02h-30h-43h-03h-CHK-0Dh

SOH-'0'-'A'-'0'-'A'-'0'-'4'-STX-'0'-'C'-ETX-CHK- CR

The monitor replies the packet for confirmation as follows;

SOH-'0'-'0'-'A'-'B'-'0'-'6'-STX-'0'-'0'-'0'-'C'-ETX-CHK- CR

#### 5.5.1a Save Current Settings Quick.

The controller requests for the monitor to store the adjusted value.

This command supports only following items, in order to shorten execute time in monitor inside.

CONTRAST, BRIGHT, Color Temperature, IR Control, Information OSD, H-Position, V-Position, Sharpness, Black Level, Tint, Color, OSD Turn Off, Off Timer, OSD H-Position, OSD V-Position, Power On Delay, Gamma Selection, Tiling, Monitor ID, Clock, Clock Phase, Zoom, H-Resolution, V-Resolution.

STX	Command code		ETX
	'0'	'D'	

- Send "0D"(30h, 44h) as Save current settings quick command.
- Complete "Save Current setting" command packet as follows;

ASCII: 01h-30h-41h-30h-41h-30h-34h-02h-30h-44h-03h-CHK-0Dh

SOH-'0'-'A'-'0'-'A'-'0'-'4'-STX-'0'-'D'-ETX-CHK- CR

The monitor replies the packet for confirmation as follows;

SOH-'0'-'0'-'A'-'B'-'0'-'6'-STX-'0'-'0'-'0'-'D'-ETX-CHK- CR

### 5.5.2 Get Timing Report and Timing reply.

The controller requests the monitor to report the displayed image timing.

STX	Command code		ETX
	'0'	'7'	

- Send "07" (30h, 37h) as Get Timing Report command.
- Complete "Get Timing Report" command packet as follows;  
(The destination "A" (monitor ID of 1) is only an example. It should be changed according to the target monitor ID)

ASCII: 01h-30h-41h-30h-41h-30h-34h-02h-30h-37h-03h-CHK-0Dh

SOH-'0'-'A'-'0'-'A'-'0'-'4'-STX-'0'-'7'-ETX-CHK- CR

The monitor replies status as the following format;

STX	Command		SS		H Freq.				V Freq.				ETX
	'4'	'E'	Hi	Lo	MSB			LSB	MSB			LSB	

- SS: Timing status byte
  - Bit 7 = 1: Sync Frequency is out of range.
  - Bit 6 = 1: Unstable count
  - Bit 5-2 Reserved (Don't care)
  - Bit 1 1:Positive Horizontal sync polarity.  
0:Negative Horizontal sync polarity.
  - Bit 0 1:Positive Vertical sync polarity.  
0:Negative Vertical sync polarity.
- H Freq: Horizontal Frequency in unit 0.01kHz
- V Freq: Vertical Frequency in unit 0.01Hz  
Ex.) When H Freq is '1'2'A'9' (31h, 32h, 41h, 39h), it means 47.77kHz.

### 5.5.3 NULL Message

STX	Command code		ETX
	'B'	'E'	

The NULL message returned from the monitor is used in the following cases;

- A timeout error has occurred. (The default timeout is 10msec for command internal gap.)
- The monitor receives an unsupported message type.
- The monitor detects a packet BCC (Block Check Code) error.
- To tell the controller that the monitor does not have any answer to give to the host (not ready or not expected)

- Complete "NULL Message" command packet as follows;
- (The destination "A" (monitor ID of 1) is only an example. It should be changed according to the target monitor ID)

```
01h-30h-30h-41h-41h-30h-34h-02h-42h-45h-03h-CHK-0Dh
SOH-'0'-'0'-'A'-'A'-'0'-'4'-'STX-'B'-'E'-'ETX-CHK- CR
```

## 6. Typical procedure example

The following is a sample of procedures to control the monitor, these are examples of "Get parameter", "Set parameter" and "Save current settings".

### 6.1. How to change the "Brightness" setting.

Step 1. The controller requests the Monitor to reply with the current brightness setting and capability to support this operation. (Get parameter)

Header	Message	Check code	Delimiter
SOH-'0'-'A'-'0'-'C'-'0'-'6'	STX-'0'-'0'-'1'-'0'-'ETX	BCC	CR

#### Header

SOH (01h): Start Of Header  
 '0' (30h): Reserved  
 'A' (41h): Monitor ID

If the command should be sent to certain monitor only, the either of character 'A' (41h) to 'Z' (5Ah) which is corresponding to monitor ID from No1 to No.26 should be set to this portion. If it is a broad cast command (only "set command" is available), then the '\*' (2Ah) should be applied.

'0' (30h): Message sender is the controller  
 'C' (43h): Message is "Get parameter command"  
 '0'-'6' (30h, 36h): Message length is 6 bytes

#### Message

STX (02h): Start of Message  
 '0'-'0' (30h, 30h): Operation code page number is 0  
 '1'-'0' (31h, 30h): Operation code is 10h (in the OP code page 0)  
 ETX (03h): End of Message

#### Check code

BCC: Block Check Code  
 Refer to the section 4.5 "Check code" for a BCC calculation.

#### Delimiter

CR (0Dh): End of packet

Step 2. The monitor replies with current Brightness setting and capability to support this operation. (If command is sent as "Broadcast" then no reply should be sent back.)

Header	Message	Check code	Delimiter
SOH-'0'-'0'-'A'-'D'-'1'-'2'	STX-'0'-'0'-'0'-'0'-'1'-'0'-'0'-'0'-'0'-'0'-'6'-'4'-'0'-'0'-'3'-'2'-'ETX	BCC	CR

#### Header

SOH (01h): Start Of Header  
 '0' (30h): Reserved

'0' (30h): Message receiver is the controller  
 'A' (41h): Monitor ID

This portion should depend on the monitor ID of Monitor. ( 'A' (41h)-'Z' (5Ah))

'D' (44h): Message Type is "Get parameter reply"  
 '1'-'2' (31h, 32h): Message length is 18 bytes

#### Message

STX (02h): Start of Message  
 '0'-'0' (30h, 30h): Result code. No error

'0'-'0' (30h, 30h): Operation code page number is 0  
 '1'-'0' (31h, 30h): Operation code is 10h (in the page 0)  
 '0'-'0' (30h, 30h): This operation is "Set parameter" type  
 '0'-'0'-'6'-'4' (30h, 30h, 36h, 34h): Brightness max value is 100(0064h)  
 '0'-'0'-'3'-'2' (30h, 30h, 33h, 32h): Current Brightness setting is 50(0032h) as 50%  
 ETX (03h): End of Message

Check code

BCC: Block Check Code

Refer to the section 4.5 "Check code" for a BCC calculation.

Delimiter

CR (0Dh): End of packet

Step 3. The controller request the monitor to change the Brightness setting

Header	Message	Check code	Delimiter
SOH-'0'-'A'-'0'-'E'-'0'-'A'	STX-'0'-'0'-'1'-'0'-'0'-'0'-'5'-'0'-ETX	BCC	CR

Header

SOH (01h): Start Of Header

'0' (30h): Reserved

'A' (41h): Monitor ID

If the command should be sent to certain monitor only, the either of character 'A'(41h) to 'Z'(5Ah) which is corresponding to monitor ID from No1 to No.26 should be set to this portion. If it is a broad cast command(only "set command" is available), then the '\*'(2Ah)should be applied.

'0' (30h): Message sender is the controller

'E' (45h): Message Type is "Set parameter command"

'0'-'A' (30h, 41h): Message length is 10 bytes

Message

STX (02h): Start of Message

'0'-'0' (30h, 30h): Operation code page number is 0

'1'-'0' (31h, 30h): Operation code is 10h (in the page 0)

'0'-'0'-'5'-'0' (30h, 30h, 35h, 30h): Set Brightness setting 80(0050h) as 80%

ETX (03h): End of Message

Check code

BCC: Block Check Code

Refer to the section 4.5 "Check code" for a BCC calculation.

Delimiter

CR (0Dh): End of packet

Step 4. The monitor replies with a message for confirmation.

(If command is sent as "Broadcast" then no reply should be sent back.)

Header	Message	Check code	Delimiter
SOH-'0'-'0'-'A'-'F'-'1'-'2'	STX-'0'-'0'-'0'-'0'-'1'-'0'-'0'-'0'-'0'-'0'-'6'-'4'-'0'-'0'-'5'-'0'-ETX	BCC	CR

Header

SOH (01h): Start Of Header

'0' (30h): Reserved

'0' (30h): Message receiver is the controller

'A' (41h): Monitor ID

This portion should depend on the monitor ID of Monitor.( 'A'(41h)-'Z'(5Ah))

'F' (46h): Message Type is "Set parameter reply"

'1'-'2' (31h, 32h): Message length is 18 bytes

Message

STX (02h): Start of Message

'0'-'0' (30h, 30h): Result code. No error

'0'-'0' (30h, 30h): Operation code page number is 0

'1'-'0' (31h, 30h): Operation code is 10h (in the page 0)

'0'-'0' (30h, 30h): This operation is "Set parameter" type  
 '0'-'0'-'6'-'4' (30h, 30h, 36h, 34h): Brightness max value is 100(0064h)  
 '0'-'0'-'5'-'0' (30h, 30h, 35h, 30h): Received a Brightness setting was 80(0050h) as 80%  
 ETX (03h): End of Message

Check code

BCC: Block Check Code  
 Refer to the section 4.5 "Check code" for a BCC calculation.

Delimiter

CR (0Dh): End of packet

- Repeat Step 1 and Step 2, if you need to check the Brightness setting. (Recommended)
- Step 5. Request the monitor to store the Brightness setting. (Save Current Settings Command)

Header	Message	Check code	Delimiter
SOH-'0'-'A'-'0'-'A'-'0'-'4'	STX-'0'-'C'-'ETX	BCC	CR

Header

SOH (01h): Start Of Header  
 '0' (30h): Reserved  
 'A' (41h): Monitor ID  
 If the command should be sent to certain monitor only, the either of character 'A'(41h) to 'Z'(5Ah) which is corresponding to monitor ID from No1 to No.26 should be set to this portion. If it is a broad cast command(only "set command" is available), then the '\*' (2Ah) should be applied.  
 '0' (30h): Message sender is the controller  
 'A' (41h): Message type is "Command"  
 '0'-'4' (30h, 34h): Message length is 4 bytes

Message

STX (02h): Start of Message  
 '0'-'C' (30h, 43h): Command code is 0Ch as "Save current settings"  
 ETX (03h): End of Message

Check code

BCC: Block Check Code  
 Refer to the section 4.5 "Check code" for a BCC calculation.

Delimiter

CR (0Dh): End of packet

## 6.2 How to read the measurement value of the built-in temperature sensors.

A2129(MDT552S/LDT552V) has two built-in temperature sensors.  
 The controller can monitor inside temperatures by using those sensors through RS-232C.

The following shows the procedure for reading the temperatures from the sensors.

Step 1. Select a temperature sensor which you want to read.

Header	Message	Check code	Delimiter
SOH-'0'-'A'-'0'-'E'-'0'-'A'	STX-'0'-'2'-'7'-'8'-'0'-'0'-'0'-'1'-'ETX	BCC	CR

Header

SOH (01h): Start of Header  
 '0' (30h): Reserved  
 'A' (41h): Monitor ID  
 If the command should be sent to certain monitor only, the either of character 'A'(41h) to 'Z'(5Ah) which is corresponding to monitor ID from No1 to No.26 should be set to this portion.

'0' (30h): Message sender is the controller  
 'E' (45h): Message Type is "Set parameter command"  
 '0'-'A' (30h, 41h): Message length is 10 bytes

Message

STX (02h): Start of Message  
 '0'-'2' (30h, 32h): Operation code page number is 02h

'7'-'8' (37h, 38h): Operation code is 78h (on page 2)  
 '0'-'0'-'0'-'1' (30h, 30h, 30h, 31h): Select the temperature sensor #1 (01h).  
     00h: No meaning  
     01h: Sensor #1  
     02h: Sensor #2  
 ETX (03h): End of Message

Check code  
 BCC: Block Check Code  
     Refer to the section 4.5 "Check code" for a BCC calculation.

Delimiter  
 CR (0Dh): End of packet

Step 2. The monitor replies for confirmation.

Header	Message	Check code	Delimiter
SOH-'0'-'0'-'A'-'F'-'1'-'2'	STX-'0'-'0'-'0'-'2'-'7'-'8'-'0'-'0'-'0'-'0' -'0'-'2'-'0'-'0'-'0'-'1'-ETX	BCC	CR

Header  
 SOH (01h): Start of Header  
 '0' (30h): Reserved  
 '0' (30h): Message receiver is the controller  
 'A' (41h): Monitor ID  
 This portion should depend on the monitor ID of Monitor.( 'A'(41h)-'Z'(5Ah))  
 'F' (46h): Message Type is "Set parameter reply"  
 '1'-'2' (30h, 32h): Message length is 18 bytes

Message  
 STX (02h): Start of Message  
 '0'-'0' (30h, 30h): Result code. No error  
 '0'-'2' (30h, 32h): Operation code page number is 02h  
 '7'-'8' (37h, 38h): Operation code is 78h (in the page 2)  
 '0'-'0' (30h, 30h): This operation is "Set parameter" type  
 '0'-'0'-'0'-'2' (30h, 30h, 30h, 32h): Number of temperature sensors 2 (0002h).  
 '0'-'0'-'0'-'1' (30h, 30h, 30h, 31h): temperature sensor is #1.  
 ETX (03h): End of Message

Check code  
 BCC: Block Check Code  
     Refer to the section 4.5 "Check code" for a BCC calculation.

Delimiter  
 CR (0Dh): End of packet

Step 3 The controller requests the monitor to send the temperature from the selected sensor.

Header	Message	Check code	Delimiter
SOH-'0'-'A'-'0'-'C'-'0'-'6'	STX-'0'-'2'-'7'-'9'-ETX	BCC	CR

Header  
 SOH (01h): Start of Header  
 '0' (30h): Reserved  
 'A' (41h): Monitor ID  
 If the command should be sent to certain monitor only, the either of character 'A'(41h) to 'Z'(5Ah) which is corresponding to monitor ID from No1 to No.26 should be set to this portion.  
 '0' (30h): Message sender is the controller  
 'C' (43h): Message Type is "Get parameter"  
 '0'-'6' (30h, 36h): Message length is 6 bytes

Message

STX (02h): Start of Message  
 '0'-'2' (30h, 32h): Operation code page number is 02h.  
 '7'-'9' (37h, 39h): Operation code is 79h (in the page 2)  
 ETX (03h): End of Message

Check code

BCC: Block Check Code  
 Refer to the section 4.5 "Check code" for a BCC calculation.

Delimiter

CR (0Dh): End of packet

Step 4. The monitor replies a temperature of selected sensor.

Header	Message	Check code	Delimiter
SOH-'0'-'0'-'A'-'D'-'1'-'2'	STX-'0'-'0'-'0'-'2'-'7'-'9'-'0'-'0'- -'0'-'0'-'F'-'F'-'0'-'0'-'3'-'2'-ETX	BCC	CR

Header

SOH (01h): Start of Header  
 '0' (30h): Reserved  
 '0' (30h): Message receiver is the controller  
 'A' (41h): Monitor ID  
 This portion should depend on the monitor ID of Monitor.( 'A'(41h)-'Z'(5Ah))  
 'D' (44h): Message Type is "Get parameter reply"  
 '1'-'2' (31h, 32h): Message length is 18 bytes

Message

STX (02h): Start of Message  
 '0'-'0' (30h, 30h): Result code. No error  
 '0'-'2' (30h, 32h): Operation code page number is 2  
 '7'-'9' (37h, 39h): Operation code is 79h (in the page 2)  
 '0'-'0' (30h, 30h): This operation is "Set parameter" type  
 '0'-'0'-'F'-'F' (30h, 30h, 46h, 46h): Maximum value.  
 '0'-'0'-'3'-'2' (30h, 30h, 33h, 32h): The temperature is **50** degrees Celsius.

Readout value is 2's complement.

Temperature [Celsius]	Readout value	
	Binary	Hexadecimal
+125.0	0000 0000 0111 1101	007Dh
+ 25.0	0000 0000 0001 1001	0019h
+ 1.0	0000 0000 0000 0001	0001h
0	0000 0000 0000 0000	0000h
- 1.0	1111 1111 1111 1111	FFFFh
- 25.0	1111 1111 1110 0111	FFE7h
- 55.0	1111 1111 1100 1001	FFC9h

ETX (03h): End of Message

Check code

BCC: Block Check Code  
 Refer to the section 4.5 "Check code" for a BCC calculation.

Delimiter

CR (0Dh): End of packet

## 7. Power control procedure

### 7.1 Power status read

1) The controller requests the monitor to reply a current power status.

Header	Message	Check code	Delimiter
SOH-'0'-'A'-'0'-'A'-'0'-'6'	STX-'0'-'1'-'D'-'6'-ETX	BCC	CR

#### Header

SOH (01h): Start Of Header  
 '0' (30h): Reserved  
 'A' (41h): Monitor ID

If the command should be sent to certain monitor only, the either of character 'A' (41h) to 'Z' (5Ah) which is corresponding to monitor ID from No1 to No.26 should be set to this portion.

'0' (30h): Message sender is the controller  
 'A' (41h): Message Type is "Command"  
 '0'-'6' (30h, 36h): Message length is 6 bytes

#### Message

STX (02h): Start of Message  
 '0'-'1'-'D'-'6': Get power status command  
 ETX (03h): End of Message

#### Check code

BCC: Block Check Code  
 Refer to the section 4.5 "Check code" for a BCC calculation.

#### Delimiter

CR (0Dh): End of packet.

2) The monitor returns with the current power status.

Header	Message	Check code	Delimiter
SOH-'0'-'0'-'A'-'B'-'1'-'2'	STX-'0'-'2'-'0'-'0'-'D'-'6'-'0'-'0'-'0'-'0'-'0'-'4'-'0'-'0'-'0'-'0'-'1'-ETX	BCC	CR

#### Header

SOH (01h): Start Of Header  
 '0' (30h): Reserved  
 '0' (30h): Message receiver is the controller  
 'A' (41h): Monitor ID  
 This portion should depend on the monitor ID of Monitor.( 'A'(41h)-'Z'(5Ah))

'B' (42h): Message Type is "Command reply"  
 '1'-'2' (31h, 32h): Message length is 18 bytes

#### Message

STX(02h):Start of Message  
 '0'-'2' (30h, 32h): Reserved data  
 '0'-'0' (30h, 30h): Result code  
     00: No Error  
     01: Unsupported  
 'D'-'6'(44h, 36h): Display power mode code  
 '0'-'0' (30h, 30h): Parameter type code is "Set parameter"  
 '0'-'0'-'0'-'4' (30h, 30h, 30h, 34h): Power mode is 4 types  
 '0'-'0'-'0'-'1' (30h, 30h, 30h, 31h): Current power mode  
     <Status>  
     0001: ON  
     0004: Sleep/Standby (power save), OFF (same as IR power off)  
     000F: Force Power OFF with OPS

ETX (03h): End of Message

#### Check code

BCC: Block Check Code  
 Refer to the section 4.5 "Check code" for a BCC calculation.

#### Delimiter



CR (0Dh): End of packet

## 7.2 Power control

1) The controller requests the monitor to control monitor power.

Header	Message	Check code	Delimiter
SOH-'0'-'A'-'0'-'A'-'0'-'C'	STX-'C'-'2'-'0'-'3'-'D'-'6'-'0'-'0'-'0'-'1'-ETX	BCC	CR

### Header

SOH (01h): Start Of Header

'0' (30h): Reserved

'A' (41h): Monitor ID

If the command should be sent to certain monitor only, the either of character 'A'(41h) to 'Z'(5Ah) which is corresponding to monitor ID from No1 to No.26 should be set to this portion. If it is a broad cast command(only "set command" is available), then the '\*'(2Ah)should be applied.

'0' (30h): Message sender is the controller

'A' (41h): Message type is "Command"

'0'-'C' (30h, 43h): Message length is 12 bytes

### Message

STX (02h): Start of Message

'C'-'2', '0'-'3'-'D'-'6' (43h, 32h, 30h, 33h, 44h, 36h): power control command

'0'-'0'-'0'-'1' (30h, 30h, 30h, 31h): Power mode

0001: ON

0002, 0003: Do not set.

0004: Sleep/Standby (power save),OFF (same as power off by IR)

000F: Force Power OFF with OPS

ETX (03h): End of Message

### Check code

BCC: Block Check Code

Refer to the section 4.5 "Check code" for a BCC calculation.

### Delimiter

CR (0Dh): End of packet.

2) The monitor replies a data for confirmation. (If command is sent as "Broadcast" then no reply should be sent back.).

Header	Message	Check code	Delimiter
SOH-'0'-'0'-'A'-'B'-'0'-'E'	STX-'0'-'0'-'C'-'2'-'0'-'3'-'D'-'6'-'0'-'0'-'0'-'1'-ETX	BCC	CR

### Header

SOH (01h): Start Of Header

'0' (30h): Reserved

'0' (30h): Message sender is the controller

'A' (41h): Monitor ID

This portion should depend on the monitor ID of Monitor.( 'A'(41h)-'Z'(5Ah)).

'B' (42h): Message type is "Command reply"

'N'-'N': Message length.

Note.) The maximum data length that can be written to the monitor at a time is 32bytes.

Ex.) The byte data 20h is encoded as ASCII characters '2' and '0' (32h and 30h).

### Message

STX (02h): Start of Message

'0'-'0' (30h, 30h): Result code. No error

'C'-'2', '0'-'3'-'D'-'6' (43h, 32h, 30h, 33h, 44h, 36h): power control reply command

2. The monitor replies same as power control command to the controller.

'0'-'0'-'0'-'1' (30h, 30h, 30h, 31h): Power mode

0001: ON

0002, 0003: Do not set.

0004: OFF (same as the power off by IR)

000F: Force Power OFF with OPS

ETX (03h): End of Message

Check code

BCC: Block Check Code

Refer to the section 4.5 "Check code" for a BCC calculation.

Delimiter

CR (0Dh): End of packet.

## 8. Asset Data read and write

### 8.1 Asset Data Read Request and reply

This command is used in order to read Asset Data.

1) The controller requests the monitor to reply with Asset data.

Header	Message	Check code	Delimiter
SOH-'0'-'A'-'0'-'A'-'0'-'A'	STX-'C'-'0'-'0'-'B'-'0'-'0'-'2'-'0'-ETX	BCC	CR

Header

SOH (01h): Start Of Header

'0' (30h): Reserved

'A' (41h): Monitor ID

If the command should be sent to certain monitor only, the either of character 'A' (41h) to 'Z' (5Ah) which is corresponding to monitor ID from No1 to No.26 should be set to this portion.

'0' (30h): Message sender is the controller

'A' (41h): Message type is "Command"

'0'-'A' (30h, 41h): Message length is 10 bytes

Message

STX (02h): Start of Message

'C'-'0'-'0'-'B' (43h, 30h, 30, 42h): Asset read request command

'0'-'0' (30h, 30h): Offset data from top of the Asset data.

At first set 00h: Read data from the top of Asset data area.

'2'-'0' (32h, 30h): Read out data length is 32bytes.

Maximum readout length is 32bytes at a time.

ETX (03h): End of Message

Check code

BCC: Block Check Code

Refer to the section 4.5 "Check code" for a BCC calculation.

Delimiter

CR (0Dh): End of packet

2) The monitor replies Asset data to the controller.

Header	Message	Check code	Delimiter
SOH-'0'-'0'-'A'-'B'-N-N	STX-'C'-'1'-'0'-'B'- Data(0)-Data(1)---Data(N)-ETX	BCC	CR

Header

SOH (01h): Start of Header

'0' (30h): Reserved

'0' (30h): Message receiver is the controller

'A' (41h): Monitor ID

This portion should depend on the monitor ID of Monitor. ('A'(41h)-'Z'(5Ah)).

'B' (42h): Message type is "Command reply"

N-N: Message length

Ex.) The byte data 20h is encoded to ASCII characters '2' and '0' (32h and 30h).

Note.) This length is includes STX and ETX.

Message

STX (02h): Start of Message

'C'-'1'-'0'-'B' (43h, 31h, 30, 42h): Asset read reply command  
 Data(0) - Data(N): Returned Asset data.  
 ETX (03h): End of Message

Check code

BCC: Block Check Code  
 Refer to the section 4.5 "Check code" for a BCC calculation.

Delimiter

CR (0Dh): End of packet

## 8.2 Asset Data write

This command is used in order to write Asset Data.

1) The controller requests the monitor to write Asset data.

Header	Message	Check code	Delimiter
SOH-'0'-'A'-'0'-'A'-N-N	STX-'C'-'0'-'0'-'E'-'0'-'0'- Data(0)-Data(1)---Data(N)-ETX	BCC	CR

Header

SOH (01h): Start Of Header  
 '0' (30h): Reserved  
 'A' (41h): Monitor ID  
 If the command should be sent to certain monitor only, the either of character 'A' (41h) to 'Z' (5Ah) which is corresponding to monitor ID from No1 to No.26 should be set to this portion. If it is a broad cast command(only "set command" is available), then the '\*' (2Ah) should be applied.  
 '0' (30h): Message sender is the controller  
 'A' (41h): Message type is "Command"  
 N-N: Message length.  
 Note.) The maximum data length that can be written to the monitor at a time is 32bytes.  
 Ex.) The byte data 20h is encoded as ASCII characters '2' and '0' (32h and 30h).

Message

STX (02h): Start of Message  
 'C'-'0'-'0'-'E' (43h, 30h, 30h, 45h): Asset Data writes command  
 '0'-'0': Offset address from top of Asset data.  
 00h: Write data from top of the Asset data area.  
 Data(0)-Data(N): Asset data. The data must be ASCII characters strings.  
 ETX (03h): End of Message

Check code

BCC: Block Check Code  
 Refer to the section 4.5 "Check code" for a BCC calculation.

Delimiter

CR (0Dh): End of packet

2) The monitor replies a data for confirmation.(If command is sent as "Broadcast" then no reply should be sent back.).

Header	Message	Check code	Delimiter
SOH-'0'-'0'-'A'-'B'-N-N	STX-'0'-'0'-'C'-'0'-'0'-'E'-'0'-'0'- Data(0)-Data(1)---Data(N)-ETX	BCC	CR

Header

SOH (01h): Start Of Header  
 '0' (30h): Reserved  
 '0' (30h): Message receiver is the controller  
 'A' (41h): Monitor ID  
 This portion should depend on the monitor ID of Monitor.( 'A' (41h)-'Z' (5Ah)).  
 'B' (42h): Message type is "Command reply"  
 N-N: Message length.  
 Note.) The maximum data length that can be written to the monitor at a time is 32bytes.  
 Ex.) The byte data 20h is encoded as ASCII characters '2' and '0' (34h and 30h).

## Message

STX (02h): Start of Message  
'0'-'0': Result code. No error  
'C'-'0'-'0'-'E' (43h, 30h, 30, 45h): Asset Data write command  
'0'-'0': Offset address from top of Asset data.  
00h : Write data into from top of the Asset data area.

Data(0) -- Data(N): Asset data. The data must be ASCII characters strings.  
ETX (03h): End of Message

## Check code

BCC: Block Check Code  
Refer to the section 4.5 "Check code" for a BCC calculation.

## Delimiter

CR (0Dh): End of packet

# 9. Date & Time read and write

## 9.1 Date & Time Read

This command is used in order to read the setting of Date & Time.

1) The controller requests the monitor to reply with the Date & Time.

Header	Message	Check code	Delimiter
SOH-'0'-'A'-'0'-'A'-'0'-'6'	STX-'C'-'2'-'1'-'1'-ETX	BCC	CR

## Header

SOH (01h): Start Of Header  
'0' (30h): Reserved  
'A' (41h): Monitor ID  
If the command should be sent to certain monitor only, the either of character 'A' (41h) to 'Z' (5Ah) which is corresponding to monitor ID from No1 to No.26 should be set to this portion.

'0' (30h): Message sender is the controller  
'A' (41h): Message type is "Command"  
'0'-'6'(30h, 36h): length.

## Message

STX (02h): Start of Message  
'C'-'2'-'1'-'1' (43h, 32h, 31h, 31h): Date & time read request command  
ETX (03h): End of Message

## Check code

BCC: Block Check Code  
Refer to the section 4.5 "Check code" for a BCC calculation.

## Delimiter

CR (0Dh): End of packet

2) The monitor replies Date & Time to the controller.

Header	Message	Check code	Delimiter
SOH-'0'-'0'-'A'-'B'-'1'-'4'	STX-'C'-'3'-'1'-'1'-YY-MM-DD-WW-HH-MM-DS-ETX	BCC	CR

## Header

SOH (01h): Start of Header  
'0' (30h):  
'0' (30h): Message receiver is the controller  
'A' (41h): Monitor ID  
This portion should depend on the monitor ID of Monitor.( 'A'(41h)-'Z'(5Ah)).  
'B' (42h): Message type is "Command reply"  
'1'-'4'(31h, 34h): Message length

## Message

STX (02h): Start of Message  
 'C'-'3'-'1'-'1' (43h, 33h, 31h, 31h): Date & Time read reply command  
 'YY'-'MM'-'DD'-'WW'-'HH'-'MN'-'DS': Date & Time data  
 YY: Year (offset 2000)  
   '0'-'0'(30h, 30h): 2000  
   |  
   '6'-'3'(36h, 33h): 2099 (99 = 63h)

MM: Month  
   '0'-'1'(30h, 31h): January  
   |  
   '0'-'C'(30h, 43h): December

DD: Day  
   '0'-'1'(30h, 31h): 1  
   |  
   '1'-'E'(31h, 45h): 30(=1Eh)  
   '1'-'F'(31h, 46h): 31(=1Fh)

WW: weekdays  
   '0'-'0'(30h, 30h): Sunday  
   '0'-'1'(30h, 31h): Monday  
   '0'-'2'(30h, 32h): Tuesday  
   '0'-'3'(30h, 33h): Wednesday  
   '0'-'4'(30h, 34h): Thursday  
   '0'-'5'(30h, 35h): Friday  
   '0'-'6'(30h, 36h): Saturday

HH: Hours  
   '0'-'0'(30h, 30h): 0  
   |  
   '1'-'7'(31h, 37h): 23 (=17h)

MN: Minutes  
   '0'-'0'(30h, 30h): 0  
   |  
   '3'-'B'(33h, 42h): 59 (=3Bh)

DS: Daylight saving (Summer time)  
   '0'-'0'(30h, 30h): NO  
   '0'-'1'(30hm 31h): YES

ETX (03h): End of Message

Check code

BCC: Block Check Code

Refer to the section 4.5 "Check code" for a BCC calculation.

Delimiter

CR (0Dh): End of packet

## 9.2 Date & Time Write

This command is used in order to write the setting of the Date & Time.

1) The controller requests the monitor to write Date & Time.

Header	Message	Check code	Delimiter
SOH-'0'-'A'-'0'-'A'-'1'-'4'	STX-'C'-'2'-'1'-'2'-'YY-MM-DD-WW-HH-MN-DS-ETX	BCC	CR

Header

SOH (01h): Start Of Header

'0' (30h): Reserved

'A' (41h): Monitor ID

If the command should be sent to certain monitor only, the either of character 'A' (41h) to 'Z' (5Ah) which is corresponding to monitor ID from No1 to No.26 should be set to this portion. If it is a broad cast command(only "set command" is available), then the '\*' (2Ah) should be applied.

'0' (30h): Message sender is the controller  
 'A' (41h): Message type is "Command"  
 '1'-'4'(31h, 34h): Message length.

Message

STX (02h): Start of Message  
 'C'-'2'-'1'-'2' (43h, 32h, 31h, 32h): Date & Time write command  
 'YY'-'MM'-'DD'-'WW'-'HH'-'MN'-'DS': Date & Time data  
 YY: Year (offset 2000)  
     '0'-'0'(30h, 30h): 2000  
     |  
     '6'-'3'(36h, 33h): 2099 (99 = 63h)  
 MM: Month  
     '0'-'1'(30h, 31h): January  
     |  
     '0'-'C'(30h, 43h): December  
 DD: Day  
     '0'-'1'(30h, 31h): 1  
     |  
     '1'-'E'(31h, 45h): 30(=1Eh)  
 WW: weekdays  
     This parameter if no use, since the week is automatically calculated by Monitor based on the date data.  
 HH: Hours  
     '0'-'0'(30h, 30h): 0  
     |  
     '1'-'7'(31h, 37h): 23 (=17h)  
 MN: Minutes  
     '0'-'0'(30h, 30h): 0  
     |  
     '3'-'B' (33h, 42h): 59 (=3Bh)  
 DS: Daylight saving (Summer time)  
     '0'-'0'(30h, 30h): NO  
     '0'-'1'(30h, 30h): YES

ETX (03h): End of Message

Check code

BCC: Block Check Code  
 Refer to the section 4.5 "Check code" for a BCC calculation.

Delimiter

CR (0Dh): End of packet

2) The monitor replies a data for confirmation.(If command is sent as "Broadcast" then no reply should be sent back.).

Header	Message	Check code	Delimiter
SOH-'0'-'0'-'A'-'B'-'1'-'6'	STX-'C'-'3'-'1'-'2'-ST-YY-MM-DD-WW-HH-MN-DS-ETX	BCC	CR

Header

SOH (01h): Start Of Header  
 '0' (30h): Reserved  
 '0' (30h): Message receiver is the controller  
 'A' (41h): Monitor ID  
     This portion should depend on the monitor ID of Monitor.( 'A'(41h)-'Z'(5Ah)).  
 'B' (42h): Message type is "Command reply"  
 '1'-'6'(31h, 36h): Message length.

Message

STX (02h): Start of Message

'C'-'3'-'1'-'2' (43h, 33h, 31h, 32h): Date & Time write reply command

ST: Date & Time Status command

'0'-'0'(30h, 30h): No error

'0'-'1'(30h, 31h): Error

'YY'-'MM'-'DD'-'WW'-'HH'-'MN'-'DS': Date & Time data

YY: Year (offset 2000)

'0'-'0'(30h, 30h): 2000

|

'6'-'3'(36h, 33h): 2099 (99 = 63h)

MM: Month

'0'-'1'(30h, 31h): January

|

'0'-'C'(30h, 43h): December

DD: Day

'0'-'1'(30h, 31h): 1

|

'1'-'E'(31h, 45h): 30(=1Eh)

'1'-'F'(31h, 46h): 31(=1Fh)

WW: weekdays

This parameter if no use, since the week is automatically calculated by Monitor based on the date data.

HH: Hours

'0'-'0'(30h, 30h): 0

|

'1'-'7'(31h, 37h): 23 (=17h)

MN: Minutes

'0'-'0'(30h, 30h): 0

|

'3'-'B' (33h, 42h): 59 (=3Bh)

DS: Daylight saving (Summer time)

'0'-'0'(30h, 30h): NO

'0'-'1'(30h, 31h): YES

ETX (03h): End of Message

Check code

BCC: Block Check Code

Refer to the section 4.5 "Check code" for a BCC calculation.

Delimiter

CR (0Dh): End of packet

## 10. Schedule read and write

### 10.1 Schedule Read

This command is used in order to read the setting of the Schedule.

1) The controller requests the monitor to read Schedule

Header	Message	Check code	Delimiter
SOH-'0'-'A'-'0'-'A'-'0'-'8'	STX-'C'-'2'-'1'-'3'-PG-ETX	BCC	CR

#### Header

SOH (01h): Start Of Header

'0' (30h): Reserved

'A' (41h): Monitor ID

If the command should be sent to certain monitor only, the either of character 'A' (41h) to 'Z' (5Ah) which is corresponding to monitor ID from No1 to No.26 should be set to this portion.

'0' (30h): Message sender is the controller

'A' (41h): Message type is "Command"

'0'-'8' (30h, 38h): Message length.

#### Message

STX (02h): Start of Message

'C'-'2'-'1'-'3' (43h, 32h, 31h, 33h): Schedule read request command

PG: Program No.

The data must be ASCII characters strings.

ETX (03h): End of Message

#### Check code

BCC: Block Check Code

Refer to the section 4.5 "Check code" for a BCC calculation.

#### Delimiter

CR (0Dh): End of packet

2) The monitor replies Schedule to the controller.

Header	Message	Check code	Delimiter
SOH-'0'-'0'-'A'-'B'-'1'-'6'	STX-'C'-'3'-'1'-'3'-PG-ON HOURS-ON MIN-OFF HOURS-OFF Min-INPUT-WD-FL-ETX	BCC	CR

#### Header

SOH (01h): Start of Header

'0' (30h): Reserved

'0' (30h): Message receiver is the controller

'A' (41h): Monitor ID

This portion should depend on the monitor ID of Monitor. ('A'(41h)-'Z'(5Ah)).

'B' (42h): Message type is "Command reply"

'1'-'6' (31h, 36h): Message length

#### Message

STX (02h): Start of Message

'C'-'3'-'1'-'3' (43h, 33h, 31h, 33h): Schedule read reply command

PG-ON HOURS-ON MIN-OFF HOURS-OFF MIN-INPUT-WD-FL: Schedule data

PG: Program No.

'0'-'0' (30h, 30h): Program No.1

|

'0'-'6' (30h, 36h): Program No.7

ON\_HOUR: Turn on time (hour)

'0'-'0' (30h, 30h): 00

|

'1'-'7' (31h, 37h): 23 (=17h)

'1'-'8' (31h, 38h): ON timer isn't set.

ON\_MIN: Turn on time (minute)

'0'-'0' (30h, 30h): 0

|

'3'-'B' (33h, 42h): 59



'3'-'C'(33h, 43h): On timer isn't set.

OFF\_HOUR: Turn off time (hour)

'0'-'0'(30h, 30h): 00

|

'1'-'7'(31h, 37h): 23 (=17h)

'1'-'8'(31h, 38h): Off timer isn't set.

OFF\_MIN: Turn off time (minute)

'0'-'0'(30h, 30h): 0

|

'3'-'B'(33h, 42h): 59 (=3Bh)

'3'-'C'(33h, 43h): Off timer isn't set.

INPUT: Timer input

'0'-'0'(30h, 30h): HDMI1

'0'-'A'(30h, 48h): HDMI2

'0'-'1'(30h, 31h): DVI-D

'0'-'2'(30h, 32h): D-SUB

'0'-'4'(30h, 34h): YPbPr(DVD/HD)

'0'-'5'(30h, 35h): VIDEO

'0'-'6'(30h, 36h): S-VIDEO

'0'-'7'(30h, 37h): It is operates by last memory input

'0'-'8'(30h, 38h): OPTION

'0'-'9'(30h, 39h): DisplayPort

WD: Week setting

bit 0: Monday

bit 1: Tuesday

bit 2: Wednesday

bit 3: Thursday

bit 4: Friday

bit 5: Saturday

bit 6: Sunday

Example)

'0'-'1'(30h, 31h): Monday

'0'-'4'(30h, 34h): Wednesday

'0'-'F'(30h, 46h): Monday, Tuesday, Wednesday and Thursday

'7'-'F'(37h, 46h): Monday to Sunday

FL: Option

bit 0: Everyday

bit 1: Every week

bit 2: Schedule Disable/Enable

\* When bit0 and bit1 are '1', it behaves as Everyday.

Example)

FL setting	Schedule	Everyweek	Everyday	Schedule behavior
'0'-'0'(30h, 30h)				Schedule Disable
'0'-'1'(30h, 31h)			0	Schedule Disable
'0'-'2'(30h, 32h)		0		Schedule Disable
'0'-'3'(30h, 33h)		0	0	Schedule Disable
'0'-'4'(30h, 34h)	0			Once *Follow WD (Week setting)
'0'-'5'(30h, 35h)	0		0	Everyday
'0'-'6'(30h, 36h)	0	0		Every week *Follow WD (Week setting)
'0'-'7'(30h, 37h)	0	0	0	Everyday

ETX (03h): End of Message

Check code

BCC: Block Check Code

Refer to the section 4.5 "Check code" for a BCC calculation.

Delimiter

CR (0Dh): End of packet

## 10.2 Schedule Write

This command is used in order to write the setting of the Schedule.

1) The controller requests the monitor to write Schedule.

Header	Message	Check code	Delimiter
SOH-'0'-'A'-'0'-'A'-'1'-'6'	STX-'C'-'2'-'1'-'4'-PG-ON HOURS-ON MIN-OFF HOURS-OFF Min-INPUT-WD-FL-ETX	BCC	CR

### Header

SOH (01h): Start Of Header

'0' (30h): Reserved

'A' (41h): Monitor ID

If the command should be sent to certain monitor only, the either of character 'A' (41h) to 'Z' (5Ah) which is corresponding to monitor ID from No1 to No.26 should be set to this portion. If it is a broad cast command (only "set command" is available), then the '\*' (2Ah) should be applied.

'0' (30h): Message sender is the controller

'A' (41h): Message type is "Command"

'1'-'6' (31h, 36h): Message length.

### Message

STX (02h): Start of Message

'C'-'2'-'1'-'4' (43h, 32h, 31h, 34h): Schedule writes command

PG-ON HOURS-ON MIN-OFF HOURS-OFF Min-INPUT-WD-FL: Schedule data

PG: Program No.

'0'-'0' (30h, 30h): Program No.1

|

'0'-'6' (30h, 36h): Program No.7

ON\_HOUR: Turn on time (hour)

'0'-'0' (30h, 30h): 00

|

'1'-'7' (31h, 37h): 23 (=17h)

'1'-'8' (31h, 38h): ON timer isn't set.

ON\_MIN: Turn on time (minute)

'0'-'0' (30h, 30h): 0

|

'3'-'B' (33h, 42h): 59

'3'-'C' (33h, 43h): On timer isn't set.

OFF\_HOUR: Turn off time (hour)

'0'-'0' (30h, 30h): 00

|

'1'-'7' (31h, 37h): 23 (=17h)

'1'-'8' (31h, 38h): Off timer isn't set.

OFF\_MIN: Turn off time (minute)

'0'-'0' (30h, 30h): 0min

|

'3'-'B' (33h, 42h): 59 (=3Bh)

'3'-'C' (33h, 43h): Off timer isn't set.

INPUT: Timer input

'0'-'0' (30h, 30h): HDMI1

'0'-'A' (30h, 41h): HDMI2

'0'-'1' (30h, 31h): DVI-D

'0'-'2' (30h, 32h): D-SUB

'0'-'4' (30h, 34h): YpbPr(DVD/HD)

'0'-'5' (30h, 35h): VIDEO

'0'-'6' (30h, 36h): S-VIDEO

'0'-'7' (30h, 37h): It is operates by last memory input

'0'-'8' (30h, 38h): OPTION

'0'-'9' (30h, 39h): DisplayPort

WD: Week setting

bit 0: Monday

bit 1: Tuesday  
bit 2: Wednesday  
bit 3: Thursday  
bit 4: Friday  
bit 5: Saturday  
bit 6: Sunday

Example)  
'0'-'1'(30h, 31h): Monday  
'0'-'4'(30h, 34h): Wednesday  
'0'-'F'(30h, 46h): Monday, Tuesday, Wednesday and Thursday  
'7'-'F'(37h, 46h): Monday to Sunday

FL: Option  
bit 0: Everyday  
bit 1: Every week  
bit 2: Schedule Disable/Enable  
\* When bit0 and bit1 are '1', it behaves as Everyday.

Example)

FL setting	Schedule	Everyweek	Everyday	Schedule behavior
'0'-'0'(30h, 30h)				Schedule Disable
'0'-'1'(30h, 31h)			0	Schedule Disable
'0'-'2'(30h, 32h)		0		Schedule Disable
'0'-'3'(30h, 33h)		0	0	Schedule Disable
'0'-'4'(30h, 34h)	0			Once *Follow WD (Week setting)
'0'-'5'(30h, 35h)	0		0	Everyday
'0'-'6'(30h, 36h)	0	0		Everyweek *Follow WD (Week setting)
'0'-'7'(30h, 37h)	0	0	0	Everyday

ETX (03h): End of Message

Check code

BCC: Block Check Code  
Refer to the section 4.5 "Check code" for a BCC calculation.

Delimiter

CR (0Dh): End of packet

2) The monitor replies a data for confirmation.(If command is sent as "Broadcast" then no reply should be sent back.).

Header	Message	Check code	Delimiter
SOH-'0'-'0'-'A'-'B'-'1'-'8'	STX-'C'-'3'-'1'-'4'-ST-PG-ON HOURS-ON MIN-OFF HOURS-OFF Min-NPUT-WD-FL-ETX	BCC	CR

Header

SOH (01h): Start Of Header  
'0' (30h): Reserved  
'0' (30h): Message receiver is the controller  
'A' (41h): Monitor ID  
This portion should depend on the monitor ID of Monitor.( 'A'(41h)-'Z'(5Ah)).  
'B' (42h): Message type is "Command reply"  
'1'-'8'(31h, 38h): Message length.

Message

STX (02h): Start of Message  
'C'-'3'-'1'-'4' (43h, 33h, 31h, 34h): Schedule writes reply command  
ST: Schedule Status command  
0(30h):No error  
1(31h):Error  
PG-ON HOURS-ON MIN-OFF HOURS-OFF Min-NPUT-WD-FL: Schedule data  
PG: Program No.  
'0'-'0'(30h, 30h): Program No.1  
|  
'0'-'6'(30h, 36h): Program No.7

ON\_HOUR: Turn on time (hour)  
 '0'-'0'(30h, 30h): 00  
 |  
 '1'-'7'(31h, 37h): 23 (=17h)  
 '1'-'8'(31h, 38h): ON timer isn't set.

ON\_MIN: Turn on time (minute)  
 '0'-'0'(30h, 30h): 0  
 |  
 '3'-'B'(33h, 42h): 59  
 '3'-'C'(33h, 43h): On timer isn't set.

OFF\_HOUR: Turn off time (hour)  
 '0'-'0'(30h, 30h): 00  
 |  
 '1'-'7'(31h, 37h): 23 (=17h)  
 '1'-'8'(31h, 38h): Off timer isn't set.

OFF\_MIN: Turn off time (minute)  
 '0'-'0'(30h, 30h): 0  
 |  
 '3'-'B'(33h, 42h): 59 (=3Bh)  
 '3'-'C'(33h, 43h): Off timer isn't set.

INPUT: Timer input  
 '0'-'0'(30h, 30h): HDMI1  
 '0'-'A'(30h, 41h): HDMI2  
 '0'-'1'(30h, 31h): DVI-D  
 '0'-'2'(30h, 32h): D-SUB  
 '0'-'4'(30h, 34h): YpbPr(DVD/HD)  
 '0'-'5'(30h, 35h): VIDEO  
 '0'-'6'(30h, 36h): S-VIDEO  
 '0'-'7'(30h, 37h): It is operates by last memory input  
 '0'-'8'(30h, 38h): OPTION  
 '0'-'9'(30h, 39h): DisplayPort

WD: Week setting  
 bit 0: Monday  
 bit 1: Tuesday  
 bit 2: Wednesday  
 bit 3: Thursday  
 bit 4: Friday  
 bit 5: Saturday  
 bit 6: Sunday

Example)  
 '0'-'1'(30h, 31h): Monday  
 '0'-'4'(30h, 34h): Wednesday  
 '0'-'F'(30h, 46h): Monday, Tuesday, Wednesday and Thursday  
 '7'-'F'(37h, 46h): Monday to Sunday

FL: Option  
 bit 0: Everyday  
 bit 1: Every week  
 bit 2: Schedule Disable/Enable  
 \* When bit0 and bit1 are '1', it behaves as Everyday.

Example)

FL setting	Schedule	Everyweek	Everyday	Schedule behavior
'0'-'0'(30h, 30h)				Schedule Disable
'0'-'1'(30h, 31h)			0	Schedule Disable
'0'-'2'(30h, 32h)		0		Schedule Disable
'0'-'3'(30h, 33h)		0	0	Schedule Disable
'0'-'4'(30h, 34h)	0			Once *Follow WD (Week setting)
'0'-'5'(30h, 35h)	0		0	Everyday
'0'-'6'(30h, 36h)	0	0		Everyweek *Follow WD (Week setting)
'0'-'7'(30h, 37h)	0	0	0	Everyday

ETX (03h): End of Message

Check code

BCC: Block Check Code

Refer to the section 4.5 "Check code" for a BCC calculation.

Delimiter

CR (0Dh): End of packet

## 11. Self diagnosis

### 11.1 Self-diagnosis status read

This command is used in order to read the Self-diagnosis status.

1) The controller requests the monitor to read Self-diagnosis status.

Header	Message	Check code	Delimiter
SOH-'0'-'A'-'0'-'A'-'0'-'4'	STX-'B'-'1'-ETX	BCC	CR

Header

SOH (01h): Start of Header

'0' (30h): Reserved

'A' (41h): Monitor ID

If the command should be sent to certain monitor only, the either of character 'A' (41h) to 'Z' (5Ah) which is corresponding to monitor ID from No1 to No.26 should be set to this portion.

'0' (30h): Message sender is the controller

'A' (41h): Message type is "Command"

'0'-'4' (30h, 34h): Message length.

Message

STX (02h): Start of Message

'B'-'1' (42h, 31h): Self-diagnosis command

ETX (03h): End of Message

Check code

BCC: Block Check Code

Refer to the section 4.5 "Check code" for a BCC calculation.

Delimiter

CR (0Dh): End of packet

2) The monitor replies a result of the self-diagnosis.

Header	Message	Check code	Delimiter
SOH-'0'-'0'-'A'-'B'-N-N	STX-'A'-'1'- ST(0)-ST(1) -----ST(n)-ETX	BCC	CR

Header

SOH (01h): Start Of Header

'0' (30h): Reserved

'0' (30h): Message receiver is the controller

'A' (41h): Monitor ID

This portion should depend on the monitor ID of Monitor.( 'A' (41h)-'Z' (5Ah)).

'B' (42h): Message type is "Command reply "

N-N: Message length.

Note.) The maximum data length that can be written to the monitor at a time is 32bytes.

Ex.) The byte data 20h is encoded as ASCII characters '2' and '0' (34h and 30h).

Message

STX (02h): Start of Message

'A'-'1' (41h, 31h): Application Test Report reply command

ST: Result of self-tests

00:Normal

80:Cooling fan-1 abnormality

81:Cooling fan-2 abnormality

90: PANEL Backlight Driver Error

The data must be ASCII characters strings.

Example) The byte data 70 is encoded as ASCII characters '7' and '0' (37h and 30h).

ETX (03h): End of Message

Check code

BCC: Block Check Code

Refer to the section 4.5 "Check code" for a BCC calculation.

Delimiter

CR (0Dh): End of packet

## 12. Serial No. & Model Name Read

### 12.1 Serial No. Read

This command is used in order to read a serial No.

1) The controller requests the monitor to read a serial No.

Header	Message	Check code	Delimiter
SOH-'0'-'A'-'0'-'A'-'0'-'6'	STX-'C'-'2'-'1'-'6'-ETX	BCC	CR

#### Header

SOH (01h): Start Of Header

'0' (30h): Reserved

'A' (41h): Monitor or ID

If the command should be sent to certain monitor only, the either of character 'A'(41h) to 'Z'(5Ah) which is corresponding to monitor ID from No1 to No.26 should be set to this portion.

'0' (30h): Message sender is the controller

'A' (41h): Message type is "Command"

'0'-'6'(30h, 36h): Message length.

#### Message

STX (02h): Start of Message

'C'-'2'-'1'-'6' (43h, 32h, 31h, 36h): Serial No. command

ETX (03h): End of Message

#### Check code

BCC: Block Check Code

Refer to the section 4.5 "Check code" for a BCC calculation.

#### Delimiter

CR (0Dh): End of packet

2) The monitor replies a data for confirmation.(If command is sent as "Broadcast" then no reply should be sent back.).

Header	Message	Check code	Delimiter
SOH-'0'-'0'-'A'-'B'-N-N	STX-'C'-'3'-'1'-'6'- Data(0)-Data(1)---Data(n)-ETX	BCC	CR

#### Header

SOH (01h): Start Of Header

'0' (30h): Reserved

'0' (30h): Message receiver is the controller

'A' (41h): Monitor ID

This portion should depend on the monitor ID of Monitor.( 'A'(41h)-'Z'(5Ah)).

'B' (42h): Message type is "Command reply "

N-N: Message length.

Note.) The maximum data length that can be written to the monitor at a time is 32bytes.

Ex.) The byte data 20h is encoded as ASCII characters '2' and '0' (32h and 30h).

#### Message

STX (02h): Start of Message

'C'-'3'-'1'-'6' (41h, 33h, 31h, 36h): Serial No. reply command

Data(0)-Data(1)----Data(n):Serial Number

The data must be ASCII characters strings.

ETX (03h): End of Message

#### Check code

BCC: Block Check Code

Refer to the section 4.5 "Check code" for a BCC calculation.

#### Delimiter

CR (0Dh): End of packet

## 12.2 Model Name Read

This command is used in order to read the Model Name.

1) The controller requests the monitor to read Model Name.

Header	Message	Check code	Delimiter
SOH-'0'-'A'-'0'-'A'-'0'-'6'	STX-'C'-'2'-'1'-'7'-ETX	BCC	CR

### Header

SOH (01h): Start Of Header

'0' (30h): Reserved

'A' (41h): Monitor ID

If the command should be sent to certain monitor only, the either of character 'A'(41h) to 'Z'(5Ah) which is corresponding to monitor ID from No1 to No.26 should be set to this portion.

'0' (30h): Message sender is the controller

'A' (41h): Message type is "Command"

'0'-'6'(30h, 36h): Message length.

### Message

STX (02h): Start of Message

'C'-'2'-'1'-'7' (43h, 32h, 31h, 37h): Model Name command

ETX (03h): End of Message

### Check code

BCC: Block Check Code

Refer to the section 4.5 "Check code" for a BCC calculation.

### Delimiter

CR (0Dh): End of packet

2) The monitor replies a data for confirmation.(If command is sent as "Broadcast" then no reply should be sent back.)

Header	Message	Check code	Delimiter
SOH-'0'-'0'-'A'-'B'-N-N	STX-'C'-'3'-'1'-'7'-Data(0) -Data(1)---- -Data(n)-ETX	BCC	CR

### Header

SOH (01h): Start Of Header

'0' (30h): Reserved

'0' (30h): Message receiver is the controller

'A' (41h): Monitor ID

This portion should depend on the monitor ID of Monitor.( 'A'(41h)-'Z'(5Ah)).

'B' (42h): Message type is "Command reply "

N-N: Message length.

Note.) The maximum data length that can be written to the monitor at a time is 32bytes.

Ex.) The byte data 20h is encoded as ASCII characters '2' and '0' (32h and 30h).

### Message

STX (02h): Start of Message

'C'-'3'-'1'-'7' (41h, 33h, 31h, 37h): Model Name reply Command

Data(0) -Data(1)----Data(n):Model name

The data must be ASCII characters strings.

ETX (03h): End of Message

### Check code

BCC: Block Check Code

Refer to the section 4.5 "Check code" for a BCC calculation.

### Delimiter

CR (0Dh): End of packet



### 13. Control Commands for Auto Brightness function

A2129(MDT552S/LDT552V) supports the Auto Brightness function via RS232c control in order to share a sensor detected result in a monitor with multiple monitors.

We have 2 modes of control.

Stand alone mode: A monitor can control the others as Master(Primary).

Remote control mode: All of monitors are controlled by Host PC as slave(Secondary).

#### 13.1 Auto Brightness Parameter Read

Read parameters about AUTO BRIGHTNESS from A monitor to Host PC.

##### 1) Read Request from PC to Monitor.

Header	Message	Check code	Delimiter
SOH-'0'-'A'-'0'-'A'-'0'-'6'	STX-'C'-'2'-'2'-'1'-ETX	BCC	CR

##### Header

SOH (01h): Start Of Header

'0' (30h): Reserved

'A' (41h): Monitor ID

If the command should be sent to certain monitor only, the either of character 'A'(41h) to 'Z'(5Ah) which is corresponding to monitor ID from No1 to No.26 should be set to this portion.

'0' (30h): Message sender is the controller

'A' (41h): Message type is "Command"

'0'-'6'(30h, 36h): Message length.

##### Message

STX (02h): Start of Message

'C'-'2'-'2'-'1' (43h,32h,32h,31h): Auto Brightness Parameter Read command

ETX (03h): End of Message

##### Check code

BCC: Block Check Code

Refer to the section 4.5 "Check code" for a BCC calculation.

##### Delimiter

CR (0Dh): End of packet

##### 2) Reply from Monitor to PC.

The monitor replies the packet for confirmation as follows;

Header	Message	Check code	Delimiter
SOH-'0'-'0'-'A'-'B'-'0'-'A'	STX-'C'-'3'-'2'-'1'-[RES]-[RES]-[VAL_H]-[VAL_L]-ETX	BCC	CR

##### Header

SOH (01h): Start Of Header

'0' (30h): Reserved

'0' (30h): Message receiver is the controller

'A' (41h): Monitor ID

'B' (42h): Message type is "Command reply "

'0'-'A' (30h, 41h): Message length.

##### Message

STX (02h): Start of Message

'C'-'3'-'2'-'1' (41h, 33h, 32h,31h): Auto Brightness Parameter Read reply Command

RES: Result code('0'(30h)-'0'(30h):Normal, ','0'(30h)-'1'(31h):Abnormal)

VAL: Auto Brightness setting parameter

bit0: LIGHT FROM BACK (1:Yes,0:No)

bit1: BACK WALL (1:Near,0:Far)

bit2: FRONT SENSOR (1:On,0:Off)

bit3: BACK SENSOR (1:On,0:Off)

bit4: Saturation(1:On,0:Off)

bit5:Video Detect(1:On,0:Off)

bit6-7:Not used

VAL\_H: ASCII code of bit4-7of data

VAL\_L: ASCII code of bit0-3 of data

Example) If Bit0 and 1 =1 and the other bits =0, (00000011)

VAL\_H='0'(0x30) VAL\_L='3'(0x33)

ETX (03h): End of Message

Check code

BCC: Block Check Code

Refer to the section 4.5 "Check code" for a BCC calculation.

Delimiter

CR (0Dh): End of packet

## 13.2 Auto Brightness Parameter Write

Send Auto Brightness Parameters from Host( PC or Primary Monitor) to Slave (Secondary) Monitors.

### 1) Write Parameters from PC to Monitor.

Header	Message	Check code	Delimiter
SOH-'0'-'*'-'0'-'A'-'0'-'8'	STX-'C'-'2'-'2'-'2'-[VAL_H]-[VAL_L]-ETX	BCC	CR

#### Header

SOH (01h): Start Of Header  
 '0' (30h): Reserved  
 '\*' (2Ah): Monitor ID (Use '\*' as "ALL" for Broadcasting of parameter)  
 '0' (30h): Message sender is the controller  
 'A' (41h): Message type is "Command"  
 '0'-'8' (30h, 38h): Message length.

#### Message

STX (02h): Start of Message  
 'C'-'2'-'2'-'2' (43h,32h,32h,32h): Auto Brightness Parameter Write command  
 VAL\_H-VAL\_L: Auto Brightness setting parameter  
 bit0: LIGHT FROM BACK (1:Yes,0:No)  
 bit1: BACK WALL (1:Near,0:Far)  
 bit2: FRONT SENSOR (1:On,0:Off)  
 bit3: BACK SENSOR (1:On,0:Off)  
 bit4: Saturation(1:On,0:Off)  
 bit5: Video Detect(1:On,0:Off)  
 bit6-7: Not used

VAL\_H: ASCII code of bit4-7of data  
 VAL\_L: ASCII code of bit0-3 of data

Example) If Bit0 =1, Bit1 =1 and the other bits =0 (0000011b),  
 then VAL\_H='0'(0x30) and VAL\_L='3'(0x33).

ETX (03h): End of Message

#### Check code

BCC: Block Check Code  
 Refer to the section 4.5 "Check code" for a BCC calculation.

#### Delimiter

CR (0Dh): End of packet

### 2) Reply from Monitor to PC.

Basically, No need reply because it is broadcasting request.

[only for reference if the write command is done with certain destination ID]

Header	Message	Check code	Delimiter
SOH-'0'-'0'-'A'-'B'-'0'-'A'	STX-'C'-'3'-'2'-'2'-[RES]-[RES]-[VAL_H]-[VAL_L]-ETX	BCC	CR

#### Header

SOH (01h): Start Of Header  
 '0' (30h): Reserved  
 '0' (30h): Message receiver is the controller  
 'A' (41h): Monitor ID  
 'B' (42h): Message type is "Command reply "  
 '0'-'A' (30h, 41h): Message length.

#### Message

STX (02h): Start of Message  
 'C'-'3'-'2'-'2' (41h, 33h, 32h,32h): Auto Brightness Parameter Write reply Command  
 RES: Result code('0'-'0'(30h, 30h):Normal, '0'-'1'(30h, 31h):Abnormal)  
 VAL\_H-VAL\_L: Auto Brightness setting parameter  
 bit0: LIGHT FROM BACK (1:Yes,0:No)  
 bit1: BACK WALL (1:Near,0:Far)  
 bit2: FRONT SENSOR (1:On,0:Off)  
 bit3: BACK SENSOR (1:On,0:Off)

bit4:Saturation(1:On,0:Off)  
bit5:Video Detect(1:On,0:Off)  
bit6-7:Not used

VAL\_H: ASCII code of bit4-7of data  
VAL\_L: ASCII code of bit0-3 of data

Example) If Bit0 =1, Bit1 =1 and the other bits =0 (00000011b),  
then VAL\_H='0'(0x30) and VAL\_L='3'(0x33).

ETX (03h): End of Message

Check code

BCC: Block Check Code

Refer to the section 4.5 "Check code" for a BCC calculation.

Delimiter

CR (0Dh): End of packet

### 13.3 Auto Brightness Sensor Read

Read light sensor detected data from Monitor to Host PC.

#### 1) Read Request from PC to Monitor.

Header	Message	Check code	Delimiter
SOH-'0'-'0'-'A'-'0'-'A'-'0'-'6'	STX-'C'-'2'-'2'-'3'-ETX	BCC	CR

##### Header

SOH (01h): Start Of Header

'0' (30h): Reserved

'A' (41h): Monitor ID

If the command should be sent to certain monitor only, the either of character 'A'(41h) to 'Z'(5Ah) which is corresponding to monitor ID from No1 to No.26 should be set to this portion.

'0' (30h): Message sender is the controller

'A' (41h): Message type is "Command"

'0'-'6'(30h, 36h): Message length.

##### Message

STX (02h): Start of Message

'C'-'2'-'2'-'3' (43h, 32h, 32h, 33h): Auto Brightness Sensor Read command

ETX (03h): End of Message

##### Check code

BCC: Block Check Code

Refer to the section 4.5 "Check code" for a BCC calculation.

##### Delimiter

CR (0Dh): End of packet

#### 2) Reply from Monitor to PC.

The monitor replies sensed data of light sensor as follows;

Note: If Auto Brightness=Off then return Null Message.

Header	Message	Check code	Delimiter
SOH-'0'-'0'-'A'-'B'-'1'-'4'	STX-'C'-'3'-'2'-'3'-[RES] -[RES] -[FVAL_HH] -[FVAL_HL] -[FVAL_LH] -[FVAL_LL] -[BVAL_HH] -[BVAL_HL] -[BVAL_LH] -[BVAL_LL] -[APL_HH] -[APL_HL] -[APL_LH] -[APL_LL]-ETX	BCC	CR

##### Header

SOH (01h): Start Of Header

'0' (30h): Reserved

'0' (30h): Message receiver is the controller

'A' (41h): Monitor ID

'B' (42h): Message type is "Command reply "

'1'-'4' (31h, 34h): Message length.

##### Message

STX (02h): Start of Message

'C'-'3'-'2'-'3' (41h, 33h, 32h,33h): Auto Brightness Sensor Read Reply Command

RES: Result code('0'(30h)-'0'(30h):Normal, ','0'(30h)-'1'(31h):Abnormal)

FVAL\_HH:Front Sensor Detected Data(High High byte)( Maximum='F'(0x46))

FVAL\_HL:Front Sensor Detected Data(High Low byte) ( Maximum='F'(0x46))

FVAL\_LH:Front Sensor Detected Data(Low High byte) ( Maximum='F'(0x46))

FVAL\_LL:Front Sensor Detected Data(Low Low byte) ( Maximum='F'(0x46))

BVAL\_HH:Back Sensor Detected Data(High High byte) ( Maximum='F'(0x46))

BVAL\_HL:Back Sensor Detected Data(High Low byte) ( Maximum='F'(0x46))

BVAL\_LH:Back Sensor Detected Data(Low High byte) ( Maximum='F'(0x46))

BVAL\_LL:Back Sensor Detected Data(Low Low byte) ( Maximum='F'(0x46))

APL\_HH:APL data(High High byte) ( Maximum='F'(0x46))

APL\_HL:APL data(High Low byte) ( Maximum='F'(0x46))

APL\_LH:APL data(LowHigh byte) ( Maximum='F'(0x46))

APL\_LL:APL data(Low Low byte) ( Maximum='F'(0x46))

ETX (03h): End of Message

##### Check code

BCC: Block Check Code

Refer to the section 4.5 "Check code" for a BCC calculation.

## 13.4 Auto Brightness Sensor Write

Broadcast light sensor data from Host(PC or Primary Monitor) to Secondary Monitors.

### 1) Write Parameters from PC to Monitors.

Header	Message	Check code	Delimiter
SOH-'0'-'*'-'0'-'A'-'1'-'2'	STX-'C'-'2'-'2'-'4'-[FVAL_HH] -[FVAL_HL]- [FVAL_LH] -[FVAL_LL] - [BVAL_HH] -[BVAL_HL] -[BVAL_LH] -[BVAL_LL] -[APL_HH] -[APL_HL] -[APL_LH] -[APL_LL] -ETX	BCC	CR

#### Header

SOH (01h): Start Of Header  
 '0' (30h): Reserved  
 '\*' (2Ah): Monitor ID (Use '\*' as "ALL" for Broadcasting of parameter)  
 '0' (30h): Message sender is the controller  
 'A' (41h): Message type is "Command"  
 '1'-'2'(31h, 32h): Message length.

#### Message

STX (02h): Start of Message  
 'C'-'2'-'2'-'4' (43h,32h,32h,34h): Auto Brightness Sensor Write command  
 FVAL\_HH:Front Sensor Detected Data(High High byte)  
 FVAL\_HL:Front Sensor Detected Data(High Low byte)  
 FVAL\_LH:Front Sensor Detected Data(Low High byte)  
 FVAL\_LL:Front Sensor Detected Data(Low Low byte)  
 BVAL\_HH:Back Sensor Detected Data(High High byte)  
 BVAL\_HL:Back Sensor Detected Data(High Low byte)  
 BVAL\_LH:Back Sensor Detected Data(Low High byte)  
 BVAL\_LL:Back Sensor Detected Data(Low Low byte)  
 APL\_HH:APL data(High High byte)  
 APL\_HL:APL data(High Low byte)  
 APL\_LH:APL data(LowHigh byte)  
 APL\_LL:APL data(Low Low byte)  
 ETX (03h): End of Message

#### Check code

BCC: Block Check Code  
 Refer to the section 4.5 "Check code" for a BCC calculation.

#### Delimiter

CR (0Dh): End of packet

### 2) Reply from Monitor to Host.

Basically, No need reply because it is broadcasting request.

[only for reference if the write command is done with certain destination ID]

Note: If Auto Brightness is not "Remote" then return Null Message.

Header	Message	Check code	Delimiter
SOH-'0'-'0'-'A'-'B'-'1'-'4'	STX-'C'-'3'-'2'-'4'-[RES]-[RES]-[FVAL_HH]- [FVAL_HL]- [FVAL_LH]-[FVAL_LL]- [BVAL_HH]-[BVAL_HL]- [BVAL_LH]-[BVAL_LL]-[APL_HH]-[APL_HL] -[APL_LH]-[APL_LL]-ETX	BCC	CR

#### Header

SOH (01h): Start Of Header  
 '0' (30h): Reserved  
 '0' (30h): Message receiver is the controller  
 'A' (41h): Monitor ID  
 'B' (42h): Message type is "Command reply "  
 '1'-'4' (31h, 34h): Message length.

#### Message

STX (02h): Start of Message  
 'C'-'3'-'2'-'4' (41h, 33h, 32h,34h): Auto Brightness Sensor Write reply Command  
 RES: Result code('0'(30h)-'0'(30h):Normal, '0'(30h)-'1'(31h):Abnormal)  
 FVAL\_HH:Front Sensor Detected Data(High High byte)

FVAL\_HL:Front Sensor Detected Data(High Low byte)  
FVAL\_LH:Front Sensor Detected Data(Low High byte)  
FVAL\_LL:Front Sensor Detected Data(Low Low byte)  
BVAL\_HH:Back Sensor Detected Data(High High byte)  
BVAL\_HL:Back Sensor Detected Data(High Low byte)  
BVAL\_LH:Back Sensor Detected Data(Low High byte)  
BVAL\_LL:Back Sensor Detected Data(Low Low byte)  
APL\_HH:APL data(High High byte)  
APL\_HL:APL data(High Low byte)  
APL\_LH:APL data(LowHigh byte)  
APL\_LL:APL data(Low Low byte)  
ETX (03h): End of Message

Check code

BCC: Block Check Code

Refer to the section 4.5 "Check code" for a BCC calculation.

Delimiter

CR (0Dh): End of packet



## 14. Control Commands for Automatic ID Assignment function

You can set sequential Monitor ID automatically for daisy chained monitors. This function is executed by following 2 steps.

Step1: Change the communication mode to "ID assignment mode" by Mode change command.  
Step2: Apply Monitor ID by Automatic ID assignment Command.

### 14.1 Mode Change Command

Change the RS232C communication mode to "ID assignment Mode".

#### 1) Write Parameters from PC to Monitors.

Header	Message	Check code	Delimiter
SOH-'0'-'*'-'0'-'A'-'0'-'4'	STX-'0'-'E'-ETX	BCC	CR

##### Header

SOH (01h): Start Of Header  
'0' (30h): Reserved  
'\*' (2Ah): Monitor ID (Use '\*' as "ALL" for Broadcasting of parameter)  
'0' (30h): Message sender is the controller  
'A' (41h): Message type is "Command"  
'0'-'4' (30h, 34h): Message length is 4 bytes.

##### Message

STX (02h): Start of Message  
'0'-'E' (30h,45h): Command code is 0Eh as "Force Mode Change"  
ETX (03h): End of Message

##### Check code

BCC: Block Check Code  
Refer to the section 4.5 "Check code" for a BCC calculation.

##### Delimiter

CR (0Dh): End of packet

#### 2) Reply from Monitor to Host.

Basically, No need reply because it is broadcasting request.

[only for reference if the write command is done with certain destination ID]

Header	Message	Check code	Delimiter
SOH-'0'-'0'-'SRC'-'B'-'0'-'6'	STX- [RES]-[RES]- '0'-'E'-ETX	BCC	CR

##### Header

SOH (01h): Start Of Header  
'0' (30h): Reserved  
'0' (30h): Message receiver is the controller  
SRC: Monitor ID  
This portion should depend on the monitor ID of Monitor.( 'A'(41h)-'Z'(5Ah))  
'B' (42h): Message type is "Command reply "  
'0'-'6' (30h, 36h): Message length is 6 bytes.

##### Message

STX (02h): Start of Message  
RES: Result code('0'(30h)-'0'(30h):Normal, \ '0'(30h)-'1'(31h):Abnormal)  
'0'-'E' (30h, 45h): Force Change Mode reply command  
ETX (03h): End of Message

##### Check code

BCC: Block Check Code  
Refer to the section 4.5 "Check code" for a BCC calculation.

##### Delimiter

CR (0Dh): End of packet

## 14.2 Automatic ID Assignment

This command executes the Automatic ID assignment operation by Monitor itself. Only start ID should be suggested by Host to 1<sup>st</sup> connected Monitor and daisy chained monitor can assign own Monitor ID one by one sequentially.

### 1) Write Parameters from PC to Monitors.

Header	Message	Check code	Delimiter
SOH-'0'-'*'-'0'-'A'-'0'-'8'	STX-'C'-'2'-'2'-'0'-[VAL]-[VAL] -ETX	BCC	CR

#### Header

SOH (01h): Start Of Header  
 '0' (30h): Reserved  
 '\*' (2Ah): Monitor ID (Use '\*' as "ALL" for Broadcasting of parameter)  
 '0' (30h): Message sender is the controller  
 'A' (41h): Message type is "Command"  
 '0'-'8' (30h, 38h): Message length is 8 bytes.

#### Message

STX (02h): Start of Message  
 'C'-'2'-'2'-'0' (41h, 32h, 32h,30h): "Exec ID Assignment"  
 VAL: Value(Start Monitor ID No. (1-26))

#### Example)

1 --- '0' (30h), '1' (31h)  
 26 --- '1' (31h), 'A' (41h)

ETX (03h): End of Message

#### Check code

BCC: Block Check Code  
 Refer to the section 4.5 "Check code" for a BCC calculation.

#### Delimiter

CR (0Dh): End of packet

### 2) Reply from Monitor to PC.

Basically, No need reply because it is broadcasting request.

[This is only for reference if the write command is done with certain destination ID]

Header	Message	Check code	Delimiter
SOH-'0'-'0'-SRC-'B'-'0'-'A'	STX-[RES]-[RES] -'C'-'2'-'2'-'0'-[VAL] -[VAL]-ETX	BCC	CR

#### Header

SOH (01h): Start Of Header  
 '0' (30h): Reserved  
 '0' (30h): Message receiver is the controller  
 SRC: Monitor ID  
 This portion depends on the monitor ID of Monitor. ('A'(41h)-'Z'(5Ah))  
 'B' (42h): Message type is "Command reply "  
 '0'-'A' (30h, 41h): Message length.

#### Message

STX (02h): Start of Message  
 RES: Result code('0'(30h)-'0'(30h):Normal, \ '0'(30h)-'1'(31h):Abnormal)  
 'C'-'2'-'2'-'0' (41h, 32h, 32h,30h): Exec ID Assignment reply command  
 VAL: ID No. suggested from Host  
 ETX (03h): End of Message

#### Check code

BCC: Block Check Code  
 Refer to the section 4.5 "Check code" for a BCC calculation.

#### Delimiter

CR (0Dh): End of packet

## Appendix

### A. Operation Code (OP code) Table

[Note: Do not send any code to monitor except for the codes in following table.

If you sent any "undefined" code to monitor, it may cause error of Monitor operation.]

	Item	OP code page	OP code	Parameter	Remarks
PICTURE	Brightness	00h	10h	0: dark   MAX.: bright	
	Contrast	00h	12h	0: low   MAX.: high	
	Sharpness	00h	8Ch	0: dull   MAX.: sharp	
	Tint	00h	90h	0:   MAX.:	
	Color	02h	1Fh	0: pale   MAX.: deep	
	Black Level	00h	92h	0: dark   MAX.: bright	
	Noise Reduction	02h	20h	0: Off   MAX.	
	Color control	00h	Red: 16h Green: 18h Blue: 1Ah	0:   MAX.	
	Gamma Selection	02h	68h	Gamma Table Selection 1: Native Gamma 4: Gamma=2.2 8: Gamma=2.4 7: S Gamma 5: Option 6: Programmable	
	Super Resolution	02h	36h	0: Off   (Step by 10) 100: Max	
	Super Resolution (RESOLUTION DETECT)	02h	37h	1:AUTO, 2:HD, 3:SD, 4:LD	
	Reserved	00h	14h		
	Color Temperature(2)	00h	0ch	0:2600K   74:10000K	100K/step
Picture reset	00h	08h	1: Reset	Momentary	
SCREEN	H Position	00h	20h	0: Left side   Max.: Right side	Depends on a display timing
	V Position	00h	30h	0: Down side   Max.: Up side	Depends on a display timing
	Clock	00h	0Eh	0:   Max.	
	Clock phase	00h	3Eh	0:   Max.	

	Item	OP code page	OP code	Parameter	Remarks
	H Resolution	02h	50h	0:   Max.	
	V Resolution	02h	51h	0:   Max.:	
	Zoom Mode	02h	CEh	1:REAL 2:custom 5:Dynamic 7:FULL 6:Normal	
	Zoom H-Expansion	02h	6Ch	0:100%   100:300%	
	Zoom V- Expansion	02h	6Dh	0:100%   100:300%	
	Zoom H-Position	02h	CCh	0: Left side   Max.: Right side	
	Zoom V-Position	02h	CDh	0: Down side   Max.: Up side	
	Screen reset	00h	06h	1: Reset	Momentary
AUDIO	Balance	00h	93h	0: Left   50:(Center)   100: Right	
	Treble	00h	8Fh	0: Min.   50:(Center)   100: Max.	
	Bass	00h	91h	0: Min.   50:(Center)   100: Max.	
	Speaker Switch	02h	CBh	0:No Mean 1:External 2:Internal	
	Audio reset	02h	31h	1: Reset	Momentary
PIP	PIP Size	02h	71h	1: Small 2: Middle 3: Large	
	PIP Audio			N/A	
	PIP Reset			N/A	Momentary
Configuration 1	Auto Setup	00h	1Eh	1: Execute	Momentary
	Auto Adjust			N/A	
	Power Save	00h	E1h	0: OFF 1: ON	
	Language	00h	68h	1:English 2:German 3:French 4:Spanish 5:Japanese 6:Italian 7:Swedish 8:Chinese	OSD Language
	Screen Saver	Gamma	02h	DBh	1:normal 2:screen saving gamma

	Item	OP code page	OP code	Parameter	Remarks
	Brightness	02h	DCh	1:normal 2:decrease brightness	
	Cooling Fan	02h	7Dh	1:Auto 2:Forced ON	
	Motion	02h	DDh	0: 0s(Off)   90: 900s	10s/step
	Color System	02h	21h	1: NTSC 2: PAL 3: SECAM 4: Auto 5: 4.43NTSC 6: PAL-60	
	Side Border Color	02h	DFh	0:Black 1: Middle 2: White	
	Factory Reset	00h	04h	1: Reset	Momentary
	Configuration Reset			N/A	

Configuration 2						
	OSD Turn Off		00h	FCh	0-4:Do not set. 5:5sec   120:120sec	
	Information OSD		02h	3Dh	0:disable information OSD 3-10: OSD timer [seconds]	
	Off Timer		02h	2Bh	0: OFF 1: 1 hour   24: 24 hours	1 hour/step
	OSD Position	H Position	02h	38h	0:   MAX.:	
		V Position	02h	39h	0:   MAX.:	
	OSD Rotation		02h	41h	0: OFF 1: 90degree Rotation 2: H MIRROR 3: V MIRROR 4: 180degree Rotation 5: 270degree Rotation	OSD Rotation
Advanced Option	Input Resolution		02h	DAh	1: Auto 2: 1024x768 3: 1280x768 4: 1360x768 9: 1366x768 5: 1400x1050 6: 1680x1050 7: 1600x1200 8: 1920x1200	
	Black Level Expansion		02h	22h	1: OFF 2: MIDDLE 3: HIGHT	

Item		OP code page	OP code	Parameter	Remarks
Input Detect		02h	40h	0: Reserved 1: Reserved 2: None (OFF) 3: Video detect 4: Auto Select	
Scan Mode		02h	E3h	1: OVER SCAN 2: UNDERSCAN	
Scan Conversion		02h	25h	1: OFF (INTERLACE) 2: Enable (IP ON/PROGRESSIVE)	
Film Mode		02h	23h	1: OFF 2: AUTO	
Monitor ID		02h	3Eh	1-26:ID	
IR Control		02h	3Fh	1: Lock (Off) 3:Primary 2: Normal 4:Secondary	
Tiling	H monitor	02h	D0h	1   5	Number of H-division
	V monitor	02h	D1h	1   5	Number of V-division
	Position	02h	D2h	1: Upper left   MAX.: Lower right	
	Mode	02h	D3h	1: Disable (OFF) 2: Enable (ON)	
	Frame comp.	02h	D5h	1: Disable (OFF) 2: Enable (ON)	
Power On Delay		02h	D8h	0: OFF (0sec) 2,4,6,8,10,20,30,40, 50:50sec	
Control the Closed Caption Function		02h	FDh	0: Disable(Off) 1: CC1 2: CC2 3: CC3 4: CC4 5: TT1 6: TT2 7: TT3 8: TT4	
Advanced Option Reset		02h	E4h	1:RESET	Momentary
Input		00h	60h	0: No mean 1: D-SUB 2: Reserved 3: HDMI1 18: HDMI2 4: DVI-D 12: YPbPr 5: VIDEO (Composite) 7: S-VIDEO 8: OPTION 9: DisplayPort	
Picture Mode		02h	1Ah	1: sRGB 3: Hi-Bright 4: Standard 5: Cinema	SRGB: PC mode only Cinema: A/V mode only
PIP ON/OFF Still ON/OFF		02h	72h	1: OFF 2: PIP 4: Still	

	Item	OP code page	OP code	Parameter	Remarks
	PIP Input	02h	73h	0: No mean 1: RGB-3(D-SUB) 2: Reserved 3: HDMI1 18:HDMI2 4: DVI-D 12:YPbPr 5: VIDEO (Composite) 7: S-VIDEO 8: OPTION 9: DisplayPort	This operation has limitation of selection. Please refer to the monitor instruction manual.
	Still Capture	02h	76h	0: Off 1: Capture	Momentary
	Audio Input	02h	2Eh	1: Audio Analog IN(PC) 2: Reserved 3: Reserved 4: HDMI1 5: DisplayPort 6: Reserved 7: OPTION(OPS ANALOG) 8: OPTION(OPS DIGITAL)	
	Mute	00h	8Dh	0,2: UNMUTE 1: MUTE	
	Volume UP/Down	00h	62h	0: whisper   100: loud	
	PIP H Position	02h	74h	0: left side   MAX.: right side	
	PIP V Position	02h	75h	0: UP side   Max.: Down side	
Temperature sensor	Select Temperature sensor	02h	78h	1: Sensor #1 2: Sensor #2	
	Readout a temperature	02h	79h	Returned value is 2's complement. Refer to section 6.2	Read only
Auto Brightness	Auto Brightness On/Off	02h	2dh	0:Off 1:Local 2:Remote 3:Auto	
	Auto Brightness Control	02h	E7h	0:Secondary 1:Primary	
CONTROL LOCK	CONTROL LOCK of Front button and IR control (ON/OFF)	00h	E3h	0:UN LOCK(Off) 1:LOCK(ON)	This LOCK is unlocked in the same manner as LOCK status of IR CONTROL.
SUPER RESOLUTION	SUPER RESOLUTION DEMO MODE	02h	3Ah	0:OFF 1:ON	
FWver	FW version	00h	C9h	High Byte: Version Low Byte: Revision	Ex. FW ver1.02 High Byte:01h Low Byte:02h

## B. Application Note for LAN based communication

The RS-232C command code is been able to execute on LAN.  
When you make your application program, you use socket port as a TCP/IP client.  
Please refer general technical documents (commercially available) of network control.

### **Preparation of system setup**

- (1) Connect with the PC, the displays and LAN HUB with LAN cable. (See page 2.)
- (2) The Main Power Switch (AC) of the display is ON. So the modes of the display are Powr On, Power Off or Sleep/Standby.
- (3) The PC is on.
- (4) Set the OSD menu "LAN SETTING".

#### **DHCP CLIENT**

Select whether to use DHCP client or not.  
Select OFF when not using it, and select ON when using it.

#### **IP ADDRESS**

Set the IP address of the monitor.  
Default address is 192.168.0.10. (It depends on model.)

#### **SUBNET MASK**

Set the gateway mask.  
Set it to 255.255.255.0 for normal use.

#### **DEFAULT GATEWAY**

Set the IP address of the gateway router to externally connect the local area including the monitor.  
Default address is 192.168.0.1. (It depends on each model.)

- (5) Read the OSD menu "LAN SETTING" for control program.

#### **PORT**

Read the port number.  
Default number is 63007. (It depends on model.)

### **Communication protocol order**

- (1) Open socket port '63007' of the display IP address on the PC as a TCP/IP client.  
(On Windows PC, the port is "Winsock". On Linux PC, the port is "socket".)
- (2) Send RS-232C command code on TCP/IP protocol from the PC.  
(Sending 'Read command' at first is recommended for confirming communication condition and display condition.)
- (3) Receive RS-232C command code on TCP/IP protocol from the display.

**Note: This LAN command protocol has no NETWORK CERTIFICATION feature. When you don't use in private network, you may change the IP address sometimes for low level security.**

#### **[Network latency with control via LAN]**

If you control A2129(MDT552S/LDT552V) via LAN interface, the network latency time will affect the control timing of serial commands.

It is out of scope of document.

Please add necessary margin of wait time and interval of each command packet, based on the maximum available latency time with your system and add appropriate error handling operation into your control program.



C. Power control timing instruction for OPS PC.

Power ON with OPS interface

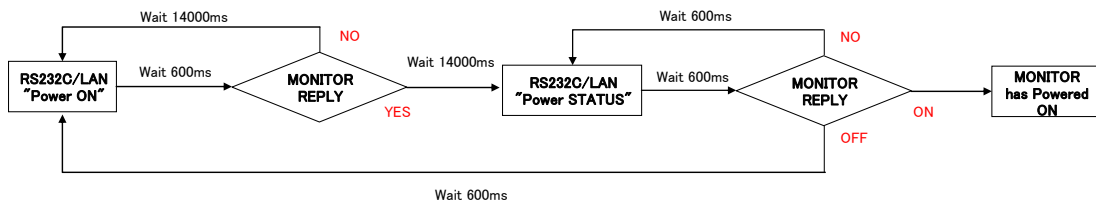

Power OFF with OPS interface

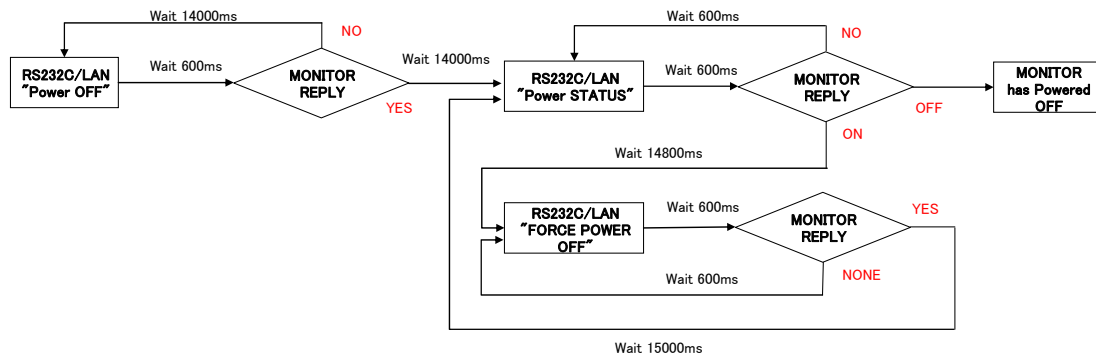

All data are subject to change without notice.

**Copyright 2008-2012 Mitsubishi Electric Corporation All Right Reserved**

This document provides the technical information for users. Mitsubishi Electric Corporation reserves the right to change or modify the information contained herein without notice. Mitsubishi Electric Corporation makes no warranty for the use of its products and bears no responsibility for any errors or omissions which may appear in this document.