

Changes for the Better



**mitsubishi
electric**

MULTIMEDIA DATA/VIDEO PROJECTORS

Big budget features

Entry-level price

4000hrs
Long Life Lamp
with lamp low mode

Instant
Shutdown

1800:1
Contrast

Optical
Zoom

Filter free
design

Carry Bag
included



SD105U

MOBILE SVGA PROJECTOR

Features	Mitsubishi Electric	Other Vendors*
4000 Hours Lamp Life	✓	X
1600 Lumens Brightness	✓	X
1800:1 Contrast Ratio	✓	✓
Optical Zoom	✓	X
Filter Free	✓	X
Instant Shutdown	✓	X
Digital Keystone Correction	✓	✓
RS232 Control	✓	✓
Kensington Lock	✓	✓
Carry Bag	✓	X

Based on comparative models



Specifications

Model	SD105U
Display technology	0.55"1-chip DMD, 12deg.DDR, DDP2000
Resolution	800 × 600 (total 480,000 pixels), 500video lines
Brightness (Maximum)	1600lm
Contrast	1800 : 1
Picture Size	40" ~ 300" (100" = 3.6m)
Source lamp**	128W (Shut Off Time 4000Hrs) with Low Mode 160W (Shut Off Time 3000Hrs)
Computer compatibility	VGA ~ XGA (640 × 480 ~ 1024 × 768), True: 800 × 600, Sync on green available
Video compatibility	NTSC / NTSC 4.43 / PAL (including PAL-M, N) / SECAM / PAL-60 Component Video: 480i/p(525i/p), 576i/p(625i/p), 720p(750p), 1080i(1125i 60Hz), 1080i(1125i 50Hz), [1080i(1250i 50Hz) is not available]
PC input terminals	RGB: mini D-sub 15pin × 1 Audio: Stereo mini jack (ø 3.5 mm) × 1
Video input terminals	Video: RCA × 1 + S - video × 1
Output terminals	RGB: mini D-sub 15pin × 1, Audio: Stereo mini jack (ø 3.5 mm) × 1
Communication terminals	USB terminal for Page Up / Down; RS232C (D-sub)
Audio speaker	2W mono
Fan noise	32dBA (Lamp Low Mode)
Dimension (W × H × D)	256 × 88 × 223 mm (excluding height adjustment)
Weight	2.9kg / 6.4lbs
Power supply	AC100 - 240V, 50 / 60Hz
Optional lamp	VLT-SD105LP

*SXGA, XGA and VGA are registered trademarks of IBM Corporation. *All brand names and product names are trademarks, registered trademarks or trade names of their respective holders.
*Fan noise is based on Mitsubishi Electric measuring standards.
*DLP (Digital Light Processing) is a trademark of Texas Instruments.
**Approximate figure representing average operational lifecycle



SD105U

MOBILE SVGA PROJECTOR

Input and Output Terminals

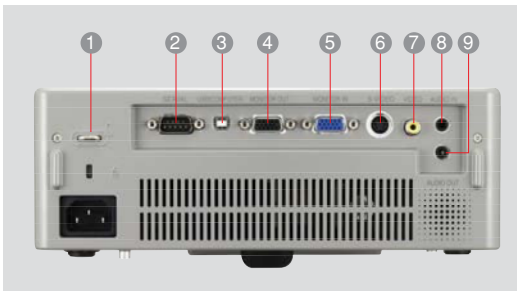

- 1 Security Hook
- 2 Serial RS-232C(D-sub 9pin)
- 3 USB terminal for mouse control
- 4 Monitor output
- 5 Monitor input
- 6 S-Video
- 7 Composite Video
- 8 Audio input
- 9 Audio output

Dimensions

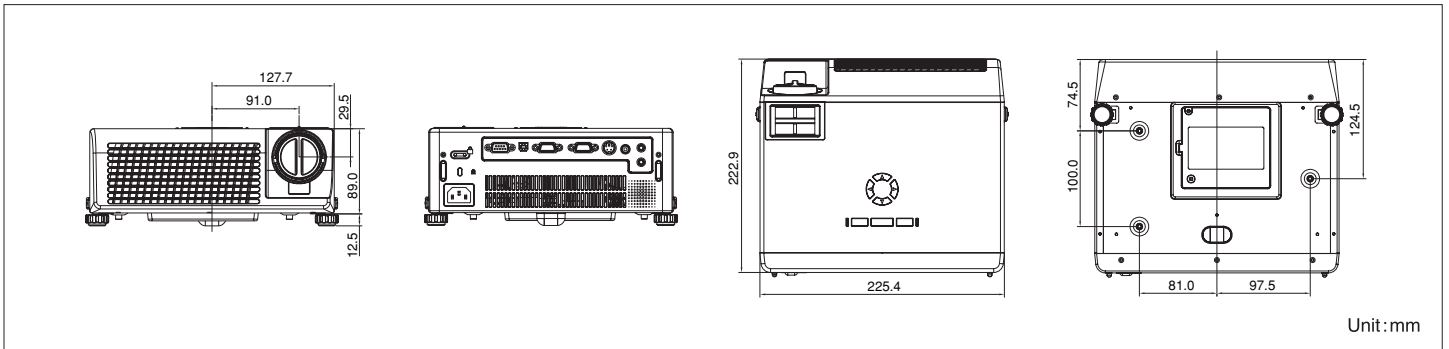

Screen size and Projection distance

Layout of the projector Image size varies depending on the distance between the screen and the projector.

Front projection

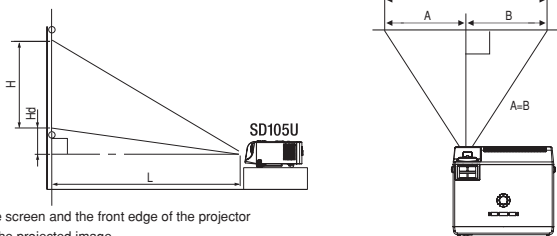

L: Between the screen and the front edge of the projector
Hd: Height of the projected image

Screen size chart (4:3 aspect ratio)

		Screen				Distance from screen (L)				Height projected image (Hd)	
Diagonal size		Width (W)		Height (H)		Maximum Zoom		Minimum Zoom		inch	
inch	cm	inch	cm	inch	cm	inch	m	inch	m	inch	cm
40	102	32	81	24	61	56	1.4	60	1.5	3.5	8.8
60	152	48	122	36	91	85	2.2	91	2.3	5.2	13.3
80	203	64	163	48	122	113	2.9	122	3.1	7.0	17.7
100	254	80	203	60	152	142	3.6	153	3.9	8.7	22.1
150	381	120	305	90	229	214	5.4	229	5.8	13.0	33.1
200	508	160	406	120	305	285	7.2	306	7.8	17.4	44.2
250	635	200	508	150	381	357	9.1	383	9.7	21.7	55.2
300	762	240	610	180	457	429	10.9	—	—	26.1	66.3

The above numbers are approximate, and may be slightly different from the actual measurements.

MITSUBISHI ELECTRIC AUSTRALIA

348 Victoria Rd Rydalmere, NSW 2116 Phone: (02) 9684 7777 Fax: (02) 9684 7208

To find out more about SD105U and our projectors, visit us at

www.MitsubishiElectric.com.au