

# MITSUBISHI ELECTRIC

## MULTIMEDIA DATA/VIDEO PROJECTORS

*Changes for the Better*



**From a mere 63cm...  
Sharp, clear wide-screen images**

**HDMI™ Ultra-short Throw Projector**  
HIGH DEFINITION MULTIMEDIA INTERFACE



# EW230U-ST



### 3 Major Functions

#### 1 Ultra-short Throw Projection

The issue of presenting in environments with limited projection space can now be eliminated with the new EW230U-ST. This native WXGA projector is equipped with an ultra-powerful short-throw lens that can project an amazing 1.52 metre (60 inch) diagonal image from a distance of just 63cm (25 inches) from the screen. With such an amazingly short projection distance, previous concerns about presenters casting their shadow on the screen are now eliminated.

**Projected Image Comparison (60-inch screen)**

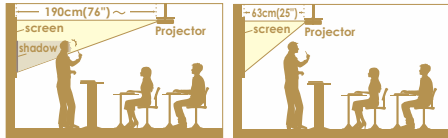

#### 2 Wide-screen Compatible

The EW230U-ST is a WXGA projector with 1280 x 800 pixel resolution specially tuned to screen aspect ratios that support the shift towards wide-screen computer monitors. It reproduces a display area 1.3 times that of conventional XGA projectors, ensuring full compatibility with wider screens and eliminating the need for left-right screen adjustment. Depending on the software installed, dual-screen projection, such as simultaneously viewing menu and preview windows is possible. DVD images can also be reproduced directly without requiring signal compression, thus providing sharper, clearer images.



Display different windows side by side, removing the need for left-right scrolling. Wide-screen broadcasts in all their natural glory.

#### 3 Network Connectivity

The EW230U-ST is equipped with a built-in LAN(RJ-45) terminal for remote operation when connected to a network. Additionally, when used with Crestron® software, integrated control of up to 250 projectors including power on/off control, message display on multiple projectors and confirmation of lamp service hours is possible using RoomView™/e-Control™ applications.

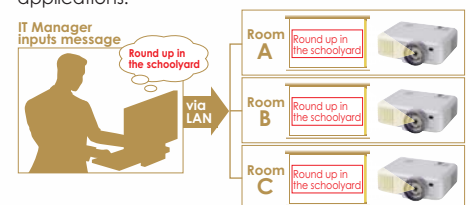

### More Functions

- 3D READY – Enjoy the future today
- A light 2.8kg, 2500lm brightness
- Silent 29dBA Operation (Low Mode)
- Colour Wall Screen support
- Direct Power Off
- Top-loading lamp\*1

\*1: A lamp replacement attachment is included to prevent the lamp from being dropped during replacement.



Top-loading lamp

- Long 4,000hr\*2 Lamp Life

\*2: When used in low lamp mode. Maximum lamp life in standard mode use is 3,000 hours. Lamp life refers to the average time required for brightness to be reduced by half, and not the time specified in the warranty. Lamp service life may vary widely depending on the environment and conditions, and whether or not cleaning and other maintenance procedures are followed.

- Stand-by Mode under 1W\*3

\*3: When LAN control is set to RS-232C, and "Stand-by Audio Out" and "Stand-by Monitor Out" are set to "Off."

- BrilliantColor™\*4 (6-segment colour wheel) Adopted

\*4: BrilliantColor is a trademark of Texas Instruments.

- 18-language On-screen Display Capable

- Dual RGB Input Terminal



# EW230U-ST

Ultra-short throw Projector

<b>Brilliant Color™</b>	<b>Wall Screen</b>	<b>Password Lock</b>	<b>Direct Power Off</b>	<b>Long-life Lamp</b>	<b>Low Standby Power</b>	<b>Picture Performance</b>
<b>Top Loading Lamp</b>	<b>Ultra-short Throw Lens</b>	<b>Lightweight Design</b>	<b>Low Fan Noise</b>	<b>LAN (RJ-45)</b>	<b>HDMI</b>	<b>User Friendly</b>

## Input and Output Terminals

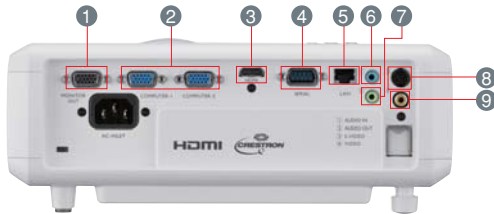

- 1 Monitor output
- 2 PC/Component video input
- 3 HDMI
- 4 Serial RS-232C
- 5 LAN (RJ-45)
- 6 Audio input
- 7 Audio output
- 8 S-Video
- 9 Video

## Dimensions

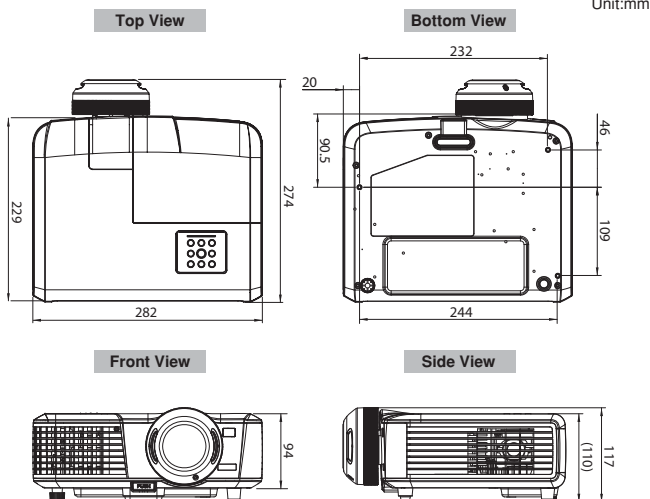

## Specifications

Model	EW230U-ST
Display Technology	0.65" 1-Chip DMD
Resolution	1280 x 800 (Total 1,024,000 pixels)
Brightness (Maximum)	2500lm
Contrast Ratio	2000 : 1
Picture Size*1	50" - 300"
Throw Ratio*1	0.5
Source Lamp	160W (4000hr*2) with Low Mode, 185W (3000hr*2) with Standard Mode
PC Compatibility	640 x 480 - 1600 x 1200, True : 1280 x 800, Sync on Green available
Video Compatibility	NTSC / NTSC 4.43 / PAL (including PAL-M, N) / SECAM / PAL-60 Component Video ; 480i/p (525i/p), 576i/p (625i/p), 720p (750p), 1080i/p (1125i/p 60Hz), 1080i/p (1125i/p 50Hz)
Input Terminals	RGB ; mini D-sub 15pin x 2 Video ; RCA x 1 + S-VIDEO x 1 Digital ; HDMI (Ver1.2) x 1 Audio ; Stereo mini jack (ø3.5mm) x 1
Output Terminals	RGB ; mini D-sub 15pin x 1 Audio ; Stereo mini jack (ø3.5mm) x 1
Communication Terminal	RS-232C; D-Sub 9pin x 1 LAN ; RJ-45 x 1
Speaker Output	2W Mono
Dimensions (W x H x D)	282 x 94 x 274mm (Not including protrusions)
Weight	2.8kg
Power Requirements	AC 100-240V, 50/60Hz
Optional Lamp	VLT-EX240LP

• Compliance with ISO21118-2005  
 • All brand names and product names are trademarks, registered trademarks or trade names of their respective holders.  
 \*1: Value may vary a few percent from that listed in the chart.  
 \*2: Approximate figure representing average operational life cycle.

## Screen size and Projection distance

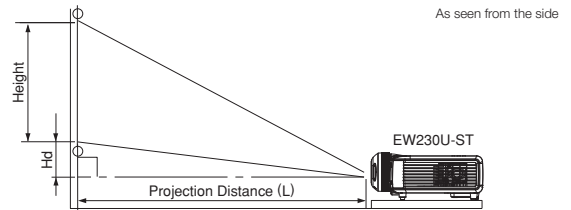

Screen size chart (16:10 aspect ratio)

Diagonal Size	Screen				Distance from screen (L)		Height projected image (Hd)		
	inch	cm	inch	cm	inch	m	inch	cm	
50	127	42	108	26	67	21	0.5	1	3
60	152	51	129	32	81	25	0.6	2	4
80	203	68	172	42	108	33	0.8	2	5
100	254	85	215	53	135	41	1.1	3	7
150	381	127	323	79	202	62	1.6	4	10
200	508	170	431	106	269	83	2.1	5	13
250	635	212	538	132	337	104	2.6	7	17
270	686	229	582	143	363	112	2.8	7	18
300	762	254	646	159	404	124	3.2	8	20

The above numbers are approximate, and may be slightly different from the actual measurements.

Screen size chart (16:9 aspect ratio)

Diagonal Size	Screen				Distance from screen (L)		Height projected image (Hd)		
	inch	cm	inch	cm	inch	m	inch	cm	
50	127	44	111	25	62	22	0.6	3	7
60	152	52	133	29	75	26	0.7	3	8
80	203	70	177	39	100	35	0.9	4	11
100	254	87	221	49	125	44	1.1	5	14
150	381	131	332	74	187	65	1.7	8	21
200	508	174	443	98	249	87	2.2	11	27
250	635	218	553	123	311	109	2.8	13	34
270	686	235	598	132	336	118	3.0	15	37
300	762	261	664	147	374	131	3.3	16	41

The above numbers are approximate, and may be slightly different from the actual measurements.

**MITSUBISHI ELECTRIC AUSTRALIA**

348 Victoria Rd Rydalmere, NSW 2116 Phone: (02) 9684 7777 Fax: (02) 9684 7208

To find out more about EW230U-ST and our projectors, visit us at

[www.MitsubishiElectric.com.au](http://www.MitsubishiElectric.com.au)