



***DIAMOND VIEW***

A TRADEMARK OF MITSUBISHI ELECTRIC AUSTRALIA PTY LTD

## **DIAMOND VIEW DV159**

---

**Colour TFT LCD Monitor**

**15" (38.1 cm) LCD Panel Size**

Copyright 2001, Mitsubishi Electric Australia Pty. Ltd. All rights reserved.

No part of this publication may be reproduced, transmitted, transcribed, stored in a retrieval system or translated into any language or computer language, in any form or by any means, electronic, mechanical, magnetic, optical, chemical, manual or otherwise, without the prior written permission.

# Table of Contents

<b>1</b>	<b>Important Safety Instructions</b> .....	<b>1</b>
<b>2</b>	<b>Features</b> .....	<b>2</b>
<b>3</b>	<b>Unpacking the Monitor</b> .....	<b>3</b>
<b>4</b>	<b>Monitor Overview</b> .....	<b>5</b>
<b>5</b>	<b>Hardware Installation</b> .....	<b>6</b>
<b>6</b>	<b>Windows Software Installation</b> .....	<b>7</b>
	Windows 95 .....	7
	Windows 98 .....	8
	Windows Me (Millennium Edition).....	8
	Windows 2000 .....	8
	Windows XP .....	9
<b>7</b>	<b>Setting the Display Resolution</b> .....	<b>11</b>
	Choosing the Best Resolution.....	11
	Supported Graphics Modes and Refresh Rate Selection	12
<b>8</b>	<b>Adjusting the Monitor</b> .....	<b>14</b>
	Picture Optimisation.....	14
	Manual Picture Adjustment .....	14
	Restoring the Factory Default Settings .....	17
	On Screen Display Functions .....	17
<b>9</b>	<b>Frequently Asked Questions</b> .....	<b>18</b>
<b>10</b>	<b>Specifications</b> .....	<b>20</b>
<b>11</b>	<b>Service Contacts</b> .....	<b>22</b>

## Disclaimer

Mitsubishi Electric Australia Pty. Ltd. makes no representations or warranties, either expressed or implied, with respect to the contents hereof and specifically disclaims any warranties, merchantability or fitness for any particular purpose. Further, Mitsubishi Electric Australia reserves the right to revise this publication and to make changes from time to time in the contents hereof without obligation to notify any person of such revision or changes.

Diamond View is a registered trademark of Mitsubishi Electric Australia Pty. Ltd.  
Microsoft and Windows are registered trademarks of Microsoft Corporation.  
All other trademarks remain the property of their respective owners.

## Reference Information

For future reference, write the following information about your monitor in the space below. The serial number is found on the back of the product or on the bottom of its stand.

### Monitor Information

Product Name: Diamond View DV159

Serial Number: \_\_\_\_\_

Date of Purchase: \_\_\_\_\_

### Dealer Information

Dealer: \_\_\_\_\_

Telephone  
Number: \_\_\_\_\_

Address: \_\_\_\_\_



## Important Safety Instructions

Please read the following safety instructions before installing or cleaning your Diamond View monitor:

1. Unplug the monitor's power cable from the wall outlet before cleaning. Do not use liquid or aerosol cleaners. Use a soft cloth to clean the monitor housing.
2. Slots and openings on the back or top of the cabinet are provided for ventilation. They must not be blocked or covered. This product should never be placed near or over a radiator or other heat source, or used in a built-in installation unless proper ventilation is provided.
3. Never push objects of any kind, or spill liquid of any kind into this product.
4. Do not attempt to service this product yourself as opening or removing covers may expose you to dangerous voltages or other hazards.
5. If any abnormal operation or accident (such as dropping the unit) occurs, disconnect the monitor from the wall power outlet and contact qualified service personnel.
6. Turn the audio volume control of the built-in speakers to minimum (0) and turn the monitor off before connecting or disconnecting any audio cable.

# Features

Your Diamond View DV159 Monitor features:

- ◆ **XGA (1024 x 768 pixel) Resolution LCD Panel**
- ◆ **High Brightness – 250 cd/m<sup>2</sup>**
- ◆ **High Contrast Ratio – 450:1**
- ◆ **True Colour Display**  
With dithering support, Diamond View DV159 monitor enhances the visual effect and offers you better image quality.
- ◆ **High Quality Ratiometric Expansion**  
With any resolution within the monitor's specified range, your Diamond View DV159 monitor can expand the image to full screen.
- ◆ **Auto Adjustment Function**  
The auto-adjustment key automatically optimises the displayed image.
- ◆ **Plug and Play Compatibility with Microsoft® Windows® 95, 98, 2000, Me and XP**
- ◆ **Space Saving - only 211.2 mm deep**
- ◆ **Light Weight - only 3.8 kg**
- ◆ **Lower Power Consumption**  
30 W maximum during operation with audio.
- ◆ **Power Saving**  
Power management complies with VESA DPMS standard. When the system is idle (in monitor off mode), the monitor automatically cuts its power consumption to less than 3 W.
- ◆ **On Screen Display**  
Allows you to adjust all settings simply using on-screen menus.
- ◆ **Built-in Stereo Amplifier and Speakers**

# 3 Unpacking the Monitor

Please check that the following items are included with your monitor. If they are missing or damaged, please contact your place of purchase immediately.

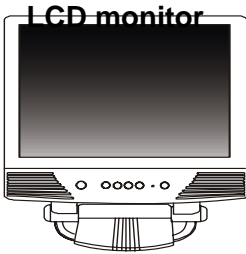

**User's Manual**



**Utilities and Driver Floppy Diskette**



**D-Sub VGA Cable**

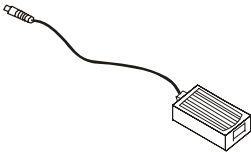

**Power Adaptor**

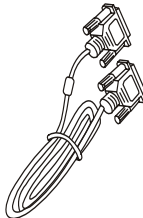

**Power Cord**

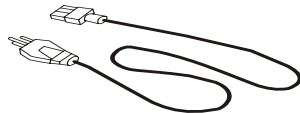

Locate the model name and the serial number label on the back of your monitor and write the details of the monitor and your place of purchase in the space on page (ii) of this manual for future reference.

# 4 Monitor Overview

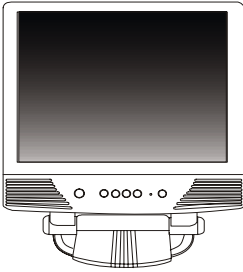

Front View

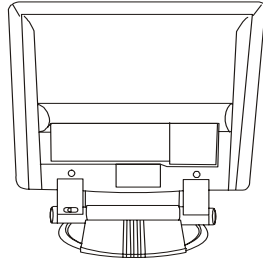

Back View

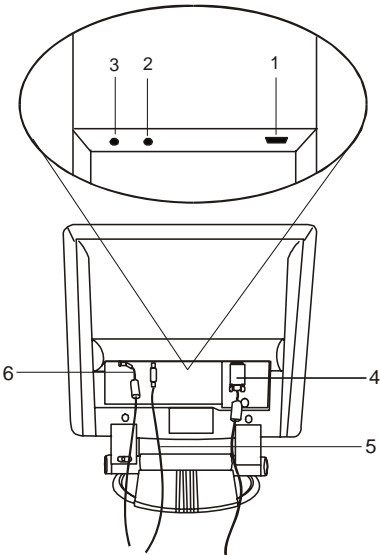

1. Video jack
2. Audio jack
3. Power jack
4. Video cable
5. Audio cable
6. Power adaptor cable

# 5 Hardware Installation

Your monitor is equipped with an AC adaptor that has a power supply with a voltage range from 100 to 240 Volts AC at a frequency of 50 to 60 Hz. Make sure that your local power supply is within the supported range. If you are unsure, please contact your electricity supplier.

To install your Diamond View DV159 monitor:

1. Make sure that the power to the computer and the power to the monitor are both turned off.
2. Connect the VGA cable from the VGA connector of the monitor to the VGA output of the computer's graphics card.
3. Connect the stereo audio cable from the monitor's audio jack to the audio output of your computer's sound card.
4. Connect power cord to the power adaptor first, and then connect the power adaptor to LCD monitor.
5. Connect the power cord from the power adaptor to an AC power socket. Please make sure, that you have easy access to the power socket so you can disconnect the unit from the power socket should you need to.

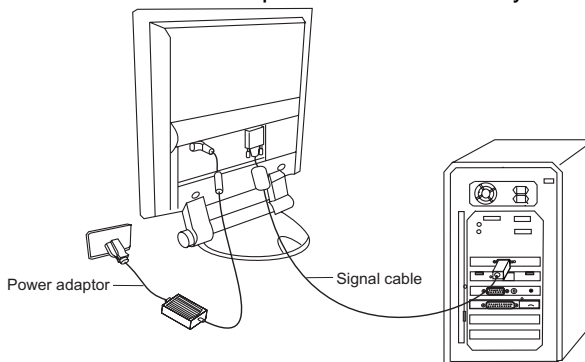
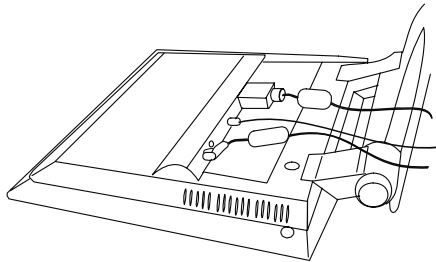

# Windows Software Installation

To get best performance with Windows 95, 98, Me, XP or 2000 you should use the Windows driver supplied with your DV159 monitor.

## Windows 95

The first time you start Windows after connecting your new monitor, the system will detect it and automatically install the driver for a Plug and Play display. To install the Diamond View DV159 driver and colour profile:

1. Insert the *Diamond View LCD Monitor Utilities* floppy disk into your floppy disk drive.
2. Right-click on the Windows desktop and select **Properties** or open the **Control Panel** and double-click **Display**.
3. From the **Display Properties** window, select the **Settings** tab and then click the **Advanced Properties** button at the bottom, right corner.
4. Select the **Monitor** tab and then click the **Change** button.
5. Click the **Have Disk** button at the bottom right corner. The **Install From Disk** window will appear with the floppy drive **A:\** selected. Click **OK**.
6. Select the **DV159** from the list and click **OK** again to install the driver.
7. You will be returned to the **Advanced Graphics Properties** dialogue box. Close this window by clicking **OK** and confirm the subsequent messages by clicking **Yes**. Click **OK** and then **Yes** once more.
8. The installation is now complete, click **OK** to close **Display Properties**.

## Windows 98

The first time you start Windows after connecting your new monitor, the system will detect it and automatically start the **Add New Hardware** wizard.

1. Click the **Next** button. Select **Search for the best driver for your device (recommended)** and click **Next**.
2. Insert the *Diamond View LCD Monitor Utilities* floppy disk into your floppy disk drive. Select the **Floppy disk drive** check box and click **Next**.
3. Click **Next** again and then click **Continue**. The driver and monitor colour profile will be installed. Click **Finish** to complete the installation.

## Windows Me (Millennium Edition)

The first time you start Windows after connecting your new monitor, the system will detect it and automatically start the **Add New Hardware** wizard.

1. Insert the *Diamond View LCD Monitor Utilities* floppy disk into your floppy disk drive. Select the **Floppy disk drive** check box and click **Next**.
2. Select **Search for the best driver for your device (recommended)**, tick the Removable Media (Floppy, CD-ROM,...) and click **Next**.
3. Click **Next** again and then **Finish** to complete the installation.

## Windows 2000

The first time you start Windows after connecting your new monitor the system may detects the DV159 monitor automatically and starts the **Add new hardware wizard**, carry out these instructions beginning at step 6. Otherwise, to install the monitor driver and ICC colour profile:

1. Right-click on the Windows desktop and select **Properties** or open the **Control Panel** and double-click **Display**.
2. From the **Display Properties** dialogue box, select the **Settings** tab. Click the **Advanced....** button at the bottom, right corner.
3. Select **Monitor** then click **Properties**.

4. Select the **Driver** tab and click **Update Driver**.
5. The **Upgrade Device Driver Wizard** will start. Click **Next**.
6. Insert the *Diamond View LCD Monitor Utilities* disk into your floppy disk drive.
7. Select **Display a list of the known drivers for this device so that I can choose a specific driver** and click **Next**.
8. In the next window, click **Have Disk**. The **Install From Disk** dialogue will open. The default drive is the floppy disk drive, **A:\**. Click **OK**.
9. Select the **DV159** LCD monitor from the list and then click **Next** twice.
10. The **Digital Signature Not Found** window may appear. If it does, click **Yes** and then click **Finish** to complete the driver installation.

## **Windows XP**

The first time you start Windows after connecting your new monitor, the system will detect it and automatically install the driver for a Plug and Play display. This default driver will operate correctly. Be sure to read chapters 7 and 8 for instructions on setting your monitor for optimal performance. If you wish to install the Diamond View DV159 monitor driver and ICC colour profile:

1. Right-click on the Windows desktop and select **Properties** or open the **Control Panel** and double-click **Display**.
2. From the **Display Properties** dialogue box, select the **Settings** tab. Click the **Advanced....** button at the bottom, right corner.
3. Select **Monitor** then click **Properties**.
4. Select the **Driver** tab and click **Update Driver...**
5. Insert the *Diamond View LCD Monitor Utilities* diskette into your floppy disk drive.
6. Select **Install the software automatically (recommended)** and click **Next**.
7. Click **Continue** and then **Finish**.

A **Hardware Installation** dialogue box may appear, informing you the monitor drivers are not **Windows Logo tested**. If it does, click **Continue Anyway** and

then click **Finish** to complete the driver installation.



# Setting the Display Resolution

## Choosing the Best Resolution

All Liquid Crystal Displays (LCDs) have a fixed resolution that is the same as the maximum resolution that may be displayed on the LCD. In the case of the DV159 the LCD resolution is 1024 x 768 pixels. This is also known as the **native** resolution of the monitor. Lower resolutions can be displayed at full screen through an interpolation circuit. However the lower resolution must be expanded and the quality of the displayed image is not as good as that available when the native resolution is displayed. For optimal performance from any LCD monitor, you must use the monitor's native resolution.

If you are using **Windows**, you can change the resolution as follows:

1. Double-click the **Display** icon in the **Control Panel**.
2. Select the **Settings** tab from the **Display Properties** dialogue box. There is a slider on the right-hand side in the middle of the dialogue box that alters the displayed resolution. Set the resolution to 1024x768.

*For Windows NT users only:* select a refresh rate of either 60 Hz or 75 Hz and click **Test**. A test pattern will be displayed. Make sure that there are no error messages shown by the monitor. If an error message is displayed, check the resolution and refresh rate settings or choose a different refresh rate.

3. Click **OK** to close **Display Properties**.

If you are using an **Apple Macintosh**, you may change the resolution by:

1. Click the Apple icon at the top, left corner of the screen, select **Control Panel** and then select **Monitors & Sound**.
2. Select a resolution of 1024 x 768 pixels with either 60 Hz or 75 Hz refresh rate.
3. If refresh rates of 60 Hz or 75 Hz are not available, click **Recommended** in the **Show** drop-down box and change it to **All**. Select the resolution and refresh rate as above.
4. A colour depth of either **Thousands** or **Millions** is recommended.

## **Supported Graphics Modes and Refresh Rate Selection**

There is no need to choose the highest possible refresh rate when using a LCD monitor. It is not technically possible for an LCD monitor to flicker. Even at a refresh rate of 60 Hz you will get an absolutely flicker-free image.

For best results, it is important that you set the graphics adaptor to use one of the monitor's preset display modes shown in **Table 1** on the next page. Other graphics signals may be displayed poorly or not at all. Note that the DV159's preset modes correspond to VESA or Apple Macintosh standard graphics signals for these resolutions. All recent models of graphics adaptor should be able to support these modes. For the native resolution of 1024 x 768 pixels, for example, refresh rates of 60, 70 and 75 Hertz are supported.

With Windows 95, 98, 2000, XP or Me you can change the refresh rate of the graphics signal as follows:

1. Double click the **Display** icon in the **Control Panel**.
2. From the **Display Properties** dialogue box, select the **Settings** tab and click the **Advanced Properties** button.
3. Select the **Adapter** tab. The refresh rate selection field is located in the centre, at the bottom of the dialogue box.
4. Choose a refresh rate that corresponds with one of the factory modes from the table below.
5. Click **Apply**, and then **OK** twice.

### **Please Note:**

- Graphics modes that are not listed in the table may not be supported. For an optimal picture it is recommended that you choose a graphics mode with a resolution of 1024 x 768 pixels that is listed in **Table 1** on the next page. Resolutions of 640 x 480, 800 x 600 and 1024 x 768 pixels are supported. The default setting may require some adjustment before use.
- The displayed image may show some distortion or noise that can be caused by the signal from the VGA card if it does not correspond with the usual standard. This is not, however, a problem with the monitor. If it is still visible

after using the Automatic adjustment, you can usually improve the displayed image by manually adjusting the phase, horizontal position and pixel frequency settings using the "Geometry" menu. See Chapter 8, **Adjusting the Monitor**, for more details.

- When you shut Windows down you may see interference lines on your screen. This caused by the manner in which Windows controls the graphics card at this point and is normal with all LCD monitors.
- To extend the service life of the product, we recommend that you use your computer's power management functions to turn the monitor off after extended idle periods.

<b>Incoming display mode (Input timing)</b>				
<b>Resolution</b>	<b>Horizontal Frequency (kHz)</b>	<b>Vertical Frequency (Hz)</b>	<b>Dot Clock Frequency (MHz)</b>	<b>Remark</b>
640x350	31.47(P)	70.08(N)	25.17	DOS
720x400	31.47(N)	70.08(P)	28.32	DOS
640x480	31.47(N)	60.00(N)	25.18	DOS
640x480	37.86(N)	72.80(N)	31.5	VESA
640x480	37.50(N)	75.00(N)	31.5	VESA
800x600	35.16(P)	56.25(P)	36.00	VESA
800x600	37.88(P)	60.32(P)	40.00	VESA
800x600	48.08(P)	72.19(P)	50.00	VESA
800x600	46.86(P)	75.00(P)	49.50	VESA
1024x768	48.36(N)	60.00(N)	65.00	VESA
1024x768	56.48(N)	70.10(N)	75.00	VESA
1024x768	60.02(P)	75.00(P)	78.75	VESA

**Table 1**

# 8 Adjusting the Monitor

## Picture Optimisation

The easiest way to obtain an optimal picture is by using the **Auto** button. This only works reliably if the graphics adaptor is set to use one of the monitor's factory modes (see **Table 1** in the previous chapter) and if you are displaying an appropriate full-screen test pattern.

Windows users should run the adjustment software (Auto.exe) from the Utilities floppy disk to display the correct test pattern. Press the **Auto** button when the test is pattern displayed. You can quit Auto.exe by clicking the left mouse button once and clicking on **Exit**.

Test patterns for other operating systems, in TIFF and JPEG file formats, are also available from the *File Downloads* section of Mitsubishi Electric Australia's web site at [www.mitsubishi-electric.com.au](http://www.mitsubishi-electric.com.au). Follow the link to the TFT LCD monitors page and download a pattern with the resolution that you need. Display the test pattern at its actual size (100% zoom), preferably at full screen and then press the monitor's **Auto** button.

The monitor will remember your settings and use them whenever you turn the monitor on. Note that you may need to readjust the monitor if it is connected to a different computer or if the computer's graphics adaptor card is replaced.

If you are still not satisfied with the result, you can enhance the image by using the monitor's manual adjustment functions.

## Manual Picture Adjustment

Adjustments to the displayed image and audio volume are made using the On-Screen Display (OSD), and the buttons on the front of the monitor.

The user's controls include Power, AUTO, increase (▲), decrease (▼), Exit and Enter.

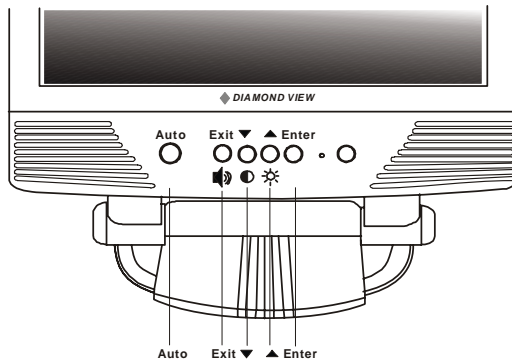

- Auto** Automatically adjusts the vertical position, pixel phase, horizontal position and pixel clock.
- Exit** Return to the main menu or exit the OSD menu without saving. Press the exit key when the OSD is not displayed to adjust the audio volume.
- Enter** Enter sub-menus, select items, save changes.
- ▼ (decrease) Reduce the value of a setting. Move the selection cursor to the left. Press to adjust Contrast if the OSD is off.
  - ▲ (increase) Increase the value of a setting. Move the selection cursor to the right. Press to adjust Brightness if the OSD is off.

To manually adjust the image:

1. Display the adjustment test pattern. This is the best way to observe changes as you adjust the image. Windows users should run the Auto.exe test pattern program provided on the Utilities floppy diskette. For non-Windows operating systems, you can use the test pattern described in the previous section or another full-screen image, for example the desktop of the operating system.
2. Open the OSD menu by pressing the **Enter** button on the monitor.
3. Press ▼ or ▲ to select the **Geometry** submenu and then press **Enter**.
4. Press ▼ or ▲ to select **Clock** and then press **Enter**.
5. Check the current setting. Increase or decrease the sampling clock to get the optimum picture. Look at the centre section of the test pattern that has

alternating black and white vertical lines that are each 1 pixel wide. There should be no vertical noise bands visible within the image. The centre section will clearly show the alternating black and white lines or a uniform level of noise will appear across the image once the clock adjustment is correct. Close the clock submenu by pressing **Exit**.

6. Select **Horizontal Position** and press **Enter**.
7. Adjust the horizontal position so that the image is centred. Its width should be the same as the visible width of the screen. Press **Exit**.
8. If some noise or distortion is still visible in the centre section of the test pattern, select **Phase** and press **Enter**.
9. Adjust the Phase of the monitor's sampling clock to optimise the displayed image. The alternating black and white lines should be clearly visible. Press **Exit**.
10. Press **Exit** twice to close the OSD menu and save your changes.

If you are still not satisfied with the result, try repeating the procedure using a graphics signal that has a different refresh rate.

**Please Note:**

You must use one of the factory modes. If the **Auto** button is not working, or the **NON PRESET MODE** message is shown on the OSD you are not using one of the supported modes. If you are having difficulties generating a supported mode, ask your computer dealer or the distributor or manufacturer of your graphics card for assistance.

The procedures described in this chapter should be performed for every resolution and type of graphics signal that you wish to use. For example, if a particular application requires a resolution of 800 x 600 pixels, but all other applications use the monitor's native resolution, you will need to display the test pattern and make adjustments twice.

The monitor will remember your settings and use them whenever you turn the monitor on. Note that you may need to re-adjust the monitor if it is connected to a different computer or if the computer's graphics adaptor card is replaced.

## Restoring the Factory Default Settings

Return to the factory settings for any display mode by pressing **Enter** to open the OSD, selecting **Miscellaneous** and then selecting **Recall**. The Recall function only affects the graphics mode that is currently displayed.

## On Screen Display Functions

The On Screen Display (OSD) provides functions that allow you to adjust the displayed image, change the audio volume, reset the monitor and get information about the displayed graphics signal.

The OSD has five functional groups for Luminance, Geometry, Colour, Information, and Miscellaneous functions.

<b>Luminance</b>	<b>Brightness and Contrast</b>
<b>Geometry</b>	<b>Horizontal and Vertical Position.</b> <b>Pixel Clock</b> – Adjusts the sampling frequency for the Analogue (VGA) to Digital signal conversion. <b>Phase</b> – Adjusts the phase of the pixel clock to eliminate sampling noise.
<b>Colour</b>	Adjust the <b>Red, Green and Blue</b> colour levels.
<b>Information</b>	<b>Information</b> – Shows the Horizontal and Vertical frequencies of the current graphics signal. <b>Recall</b> – Resets the display to factory defaults.
<b>Miscellaneous</b>	<b>OSD Setting</b> – Change the OSD position. <b>Language</b> – Select from 8 OSD languages. <b>OSD Time</b> – Sets the time limit (in sec) the OSD will be displayed on the screen. <b>Volume</b> – Sets the audio volume for the speakers.

# 9 Frequently Asked Questions

## The image is blurred, how can I get the best quality picture?

- ◆ Read chapter 7, *Setting the Display Resolution*, and select a graphics signal with the correct resolution and refresh rate. Then read chapter 7, *Adjusting the Monitor*, and make adjustments to the displayed image based on these instructions.
- ◆ Have you used a VGA extension cable?  
If so, remove the extension cable and check the displayed image. Is the image quality improved? Optimise the image using the procedures in chapter 8 with the extension cable removed. Reconnect the extension cable once the image has been optimised. Depending on the characteristics and type of the extension cable, some blurring or distortion may occur due to conduction losses of the extension cable. You can minimise these losses by using an extension cable with better conduction quality or with a built-in booster.
- ◆ Does the blurring only occur at resolutions lower than the native (maximum) resolution?

Please read chapter 7, *Setting the Display Resolution*. Select a graphics signal that uses the monitor's the native resolution (1024 x 768 pixels).

## Why does the image look yellow, blue or pink instead of showing the correct colours?

- ◆ The most common cause of this problem is a loose VGA signal cable or connector. Check that the cable is securely connected to the computer.
- ◆ Check the VGA signal cable for damage. If any pins are bent or broken off, contact your dealer or an authorised Mitsubishi Electric service agent (see Chapter 11 for details).
- ◆ Check the monitor's colour settings. Press the **Enter** button and use the wheel to select the Color Settings menu. Select the **Recall** menu item and press **Enter**.

### **No image is displayed, what can I do?**

- ◆ Check that the light (LED) next to the monitor's power button is lit and is green in colour. If the LED is green, press the **Exit** button on the monitor to access the On Screen Display. If the message *NON PRESET MODE* appears there, please read chapter 7, Setting the Display Resolution and reset the graphics card to one of the monitor's supported graphics signals.
- ◆ If the LED is orange the monitor is in power saving mode. Press a button on the computer keyboard or move the mouse to wake the computer. If that does not help, check that the VGA cable is securely plugged into the computer. Also check the pins of the VGA cable's connector. If any pins are bent or broken off, then contact your dealer (see Chapter 11 for details).
- ◆ If the LED is not lit at all, check that the monitor is plugged into the power supply mains socket and that the power switch is turned on. Check that the monitor's power switch is also turned on.

### **The image is or distorted, flashes or flickers:**

- ◆ Check that the monitor's signal cable is securely connected to the computer.
- ◆ Read the chapters 7 and 8 of this manual, then select the correct resolution, refresh rate and make adjustments based on these instructions.

### **The image is displaced in one direction:**

- ◆ Use the **Hor. Position** (horizontal position) adjustment in the Geometry menu of the monitor's OSD to reposition the image.
- ◆ Read the chapters 7 and 8 and then select the correct resolution, refresh rate and make adjustments based on these instructions.

# IO Specifications

Model: Diamond View DV159

## Display Characteristics

<b>Display Type</b>	15" active matrix Thin Film Transistor Liquid Crystal Display
<b>Viewable Diagonal Area</b>	38.1 cm / 15"
<b>Native (Maximum) Resolution</b>	1,024 x 768 pixels
<b>Colours</b>	16.7 million
<b>Contrast Ratio</b>	450:1 (typical)
<b>Brightness</b>	250 cd/m <sup>2</sup> (typical)
<b>Response Time</b>	16 ms (typical)
<b>Viewing Angle (Horizontal, Vertical)</b>	+60°/-60°, +40°/-60° (typical)
<b>Dot Pitch</b>	0.3 mm

## User Interface

<b>Controls</b>	Mains power switch, Automatic image adjustment, 4 OSD buttons
<b>On-Screen Display Functions</b>	Contrast, Brightness, Vert. & Hor. Image Position, Phase, Pixel Clock, Colour Balance, Colour Palette, Choice of language (8 language OSD), OSD Position, Status Indicator
<b>Microprocessor Controlled Graphics Modes</b>	12 modes: 9 VESA modes, 3 DOS modes

## **Input Signal**

<b>Line Frequency</b>	31.5 - 63 kHz multi-frequency
<b>Image Frequency (Refresh Rate)</b>	56.3 - 75.0 Hz Within the parameters detailed in chapter 7
<b>Video Signal</b>	RGB analogue (Positive polarity) 0.7 Vpp/75 Ohm
<b>Synchronization</b>	TTL separate, composite TTL
<b>Signal Connection</b>	15-pin mini D-sub cable

## **Physical Characteristics**

<b>Power Management</b>	VESA DPMS, Energy Star
<b>Maximum Power Consumption</b>	30 Watts
<b>Power Saving Mode</b>	< 3 Watts
<b>Operating Voltage</b>	Automatic switched mode power supply, 100 - 240 V, 50 - 60 Hz
<b>Dimensions (W x H x D)</b>	356 x 383 x 211.2 mm
<b>Weight (Net)</b>	3.5 kg
<b>Temperature (Operating)</b>	0°C - 40°C
<b>Air Humidity (Operating)</b>	20% - 85%

## **Regulatory Certification**

<b>Safety</b>	AS/NZS 60950, TUV, UL, CSA
<b>EMI/EMC</b>	AS/NZS 3548 (C-Tick), CE, FCC
<b>Other</b>	MPR-II



## Service Contacts

If problems remain after checking this manual, please contact your place of purchase or contact:

### **Australia**

Visit the Customer Support section of Mitsubishi Electric Australia's web site at

**[www.mitsubishi-electric.com.au](http://www.mitsubishi-electric.com.au)**

for details of your nearest Mitsubishi Electric Authorized Service Center or contact the Service Department for your state:

### **New South Wales and Australian Capital Territory**

348 Victoria Road

Rydalmere, NSW, 2116

Telephone: 1300 651-808

Fax: (02) 9684-7684

### **Queensland**

1 / 104 Newmarket Road

Windsor, QLD, 4030

Telephone: (07) 3357-8877

Fax: (07) 3357-8488

### **South Australia and Northern Territory**

77 Port Road

Hindmarsh, SA, 5007

Telephone: (08) 8340-0444

Fax: (08) 8340-0555

## **Victoria and Tasmania**

4 / 303 Burwood Hwy

East Burwood, VIC, 3151

Telephone: (03) 9262-9899

Fax: (03) 9262-9850

## **Western Australia**

5 / 329 Collier Road

Bassendean, WA, 6054

Telephone: (08) 9377-3411

Fax: (08) 9377-3499

---

---

## **New Zealand**

Contact:

BDT New Zealand Ltd.

1 Parliament St.

Lower Hutt

Wellington

Telephone: (04) 560-9100

Fax: (04) 560-9140

Web site: **[www.bdt.co.nz](http://www.bdt.co.nz)**